

COMADEX

Comato[®]

Inserts

Multi blade

Grooveturn

NC system

Mini system

T300 system

C10, C25, C50

Quadro System

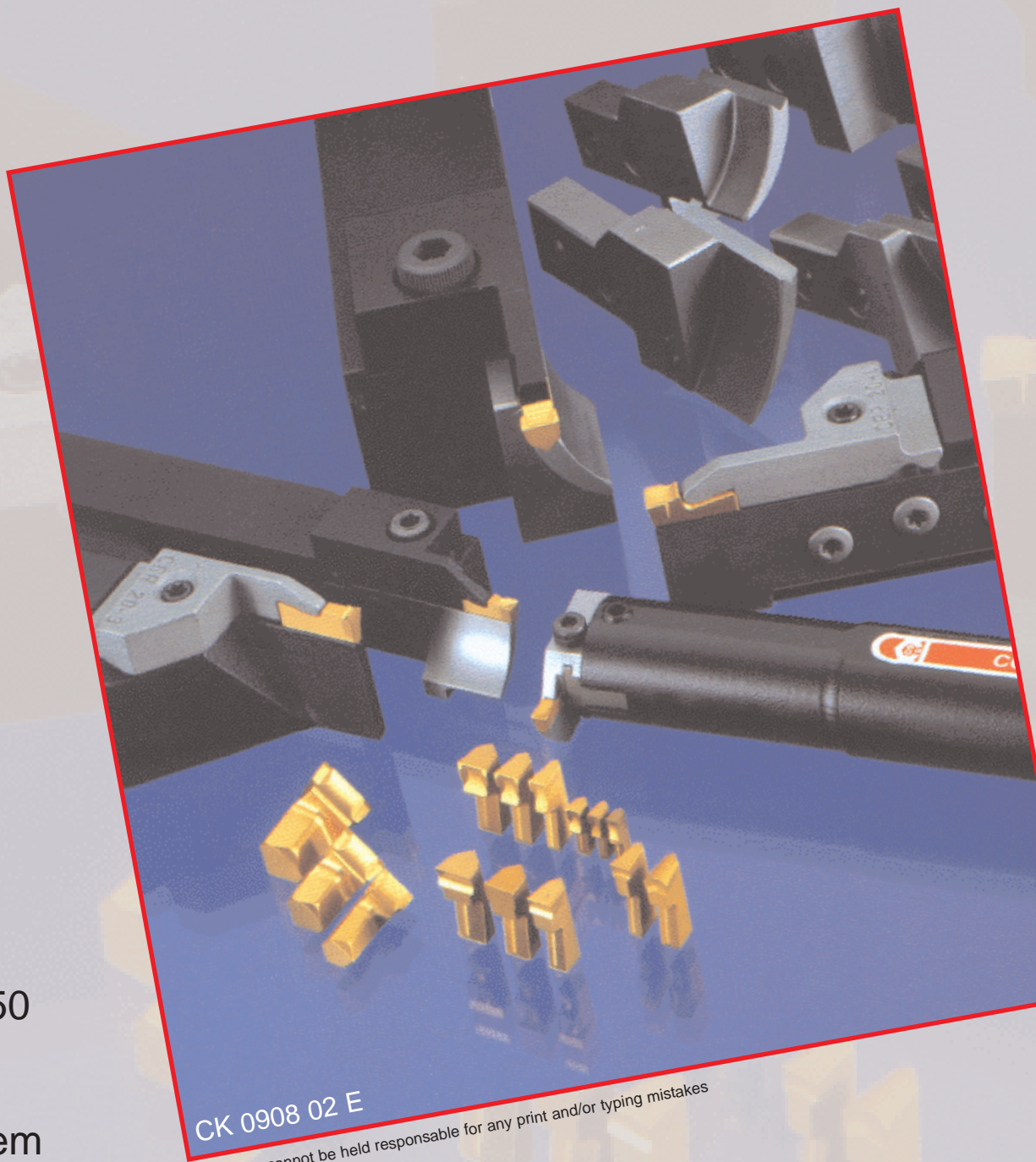

CK 0908 02 E

Comadex cannot be held responsible for any print and/or typing mistakes

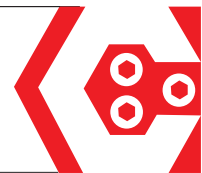

EXTERNAL GROOVING AND PARTING-OFF

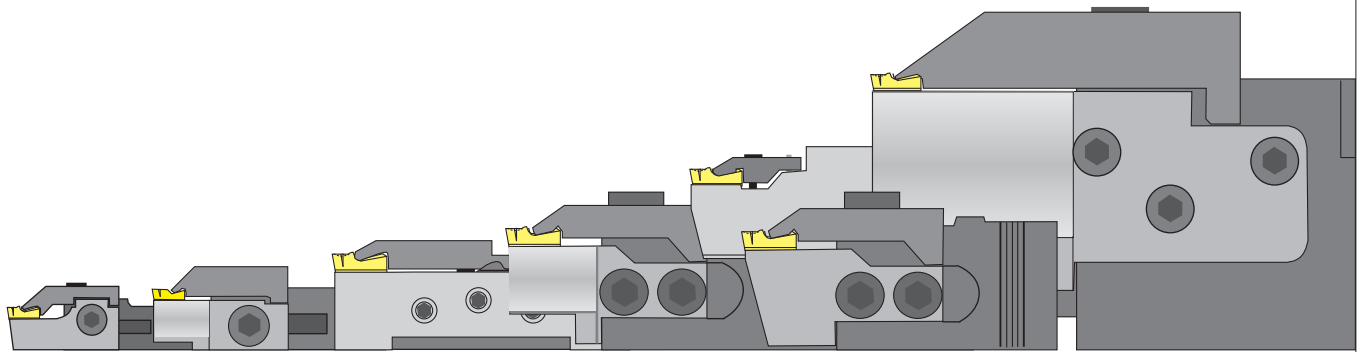

COMATO SYSTEM	GROOVING & PARTING-OFF		FACE GROOVING			Catalog page
	Groove range, mm.		Groove range, mm.			
	Cutting-width (CW)	Cutting-depth (CD)	Cutting - width (CW)	Cutting - depth (CD)	Outer Ø min.	
MINI PARTING-OFF SYSTEM	1,1-2,5	12-16	-	-	-	15
MINI-SYSTEM	2-3	16-20	1,1-2,5	8-12	20-48	16-17
GROOVETURN SYSTEM	3-5	20-40	-	-	-	18-19
NC-MODULAR SYSTEM	2-10	16-40	3-10	10-45	40->	20-29
MULTI-BLADE	4-8	32-100	-	-	-	30 / 42
T300 SYSTEM	10	50-100	6-10	50-100	70->	31-33
QUADRO HSSC	0,7-2,5	13-20	-	-	-	37-39
QUADRO HM	0,7-5	10	-	-	-	40-41

INTERNAL GROOVING

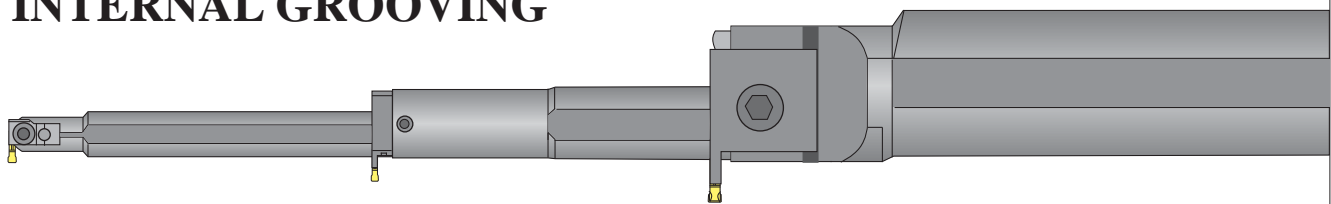

COMATO SYSTEM	INTERNAL GROOVING			Catalog page
	Minimum operating Ø	Grooving range, mm.		
		Cutting-width (CW)	Cutting-depth (CD)	
C10 system	10	1,1-2,5	2-4	34
C25 system	25	2-4	5,5-10	35
C50 system	50	3-5	12	36

GENERAL

Technical information

Technical information on grooving and parting-off
 Technical information on face grooving

page:

2 / 5
 21

Comato inserts

Inserts for external and internal grooving
 Inserts for external threading
 Inserts for external and internal circlips
 Inserts for internal grooving in small diameters

6 - 9
 10
 10 - 11
 12 - 13

EXTERNAL TOOLHOLDER SYSTEMS

Comato Mini parting-off system

Mini parting-off toolholders and spare parts

15

Comato Mini system for radial grooving and face grooving

Mini toolholders and spare parts for radial grooving and parting-off
 Mini spare parts for face grooving

16
 17

Comato GROOVETURN system

GROOVETURN toolholders
 GROOVETURN spare parts for radial grooving and parting-off

18
 19

Comato NC-modular system

NC toolholders with normal schank
 NC toolholders for BTS
 NC spare parts for radial grooving and parting-off
 NC spare parts for external face grooving
 NC spare parts for external face grooving with extra cutting depth
 NC spare parts for external face grooving, CONTRA typ

20
 21
 22
 24 - 25
 26 - 27
 28 - 29

Comato double-ended Multi-Blade

Double-ended Multi-Blades and clamps for radial grooving and parting-off

30 / 42

Comato T300 System, FOR EXTRA HEAVY GROOVING AND PARTING-OFF

T300 toolholders
 T300 spare parts for radial grooving and parting-off
 T300 spare parts for face grooving

31
 31
 32 - 33

INTERNAL TOOLHOLDER SYSTEMS

Comato C10 system

Toolholder and spare parts for internal grooving, min. operating diameter 10 mm

34

Comato C25 system

Toolholder and spare parts for internal grooving, min. operating diameter 25 mm

35

Comato C50 system

Toolholder and spare parts for internal grooving, min. operating diameter 50 mm

36

HSS PARTING-OFF AND CARBIDE GROOVING SYSTEMS

Comato QUADRO - HSSC

Toolholders, four cutting-edge HSS coated inserts for burr-free parting-off and grooving

37 - 39

Comato QUADRO - HM

Toolholders, four cutting-edge carbide coated inserts for precision grooving and/or circlips

40 - 41

STOCK INDICATION

- Comato central stock standard
- Comato semi standard
- New product, limited stock

CK-0908-01

subject to change without notice.

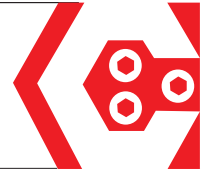

INSERTS FEATURES AND BENEFITS

All Comato* Tools in this catalogue use the patented triple-V insert clamping system, this means that **every** Comato insert in this catalogue fits in **every** toolholder system; You only have to consider the cutting width of the insert (and for internal operations the boring Ø).

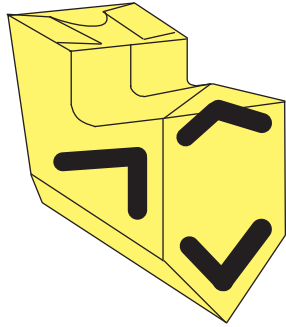

Comato's unique **TRIPLE-V** insert design offers you;

- ✓ Exact and rigid system with high indexability.
- ✓ Parting-off, grooving, face grooving and side turning possible with the same insert.
- ✓ Same insert clamping system for all toolholder systems in this catalogue.

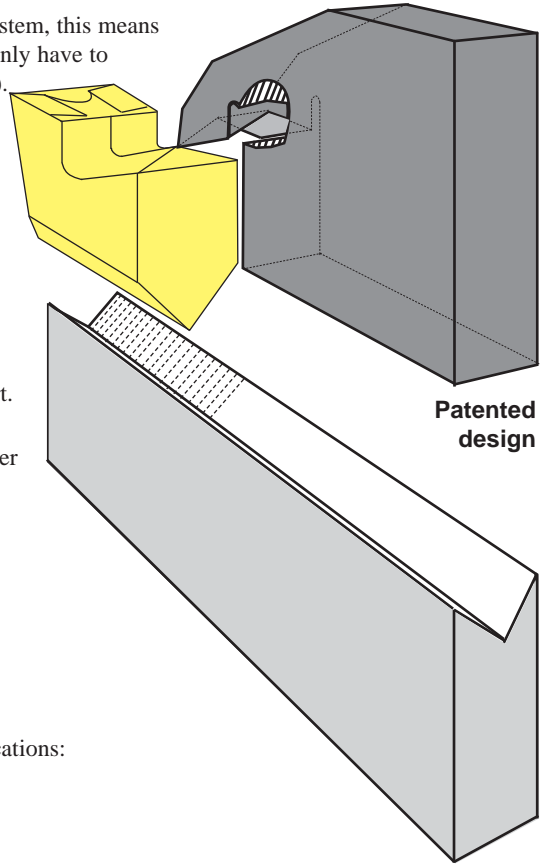

All tools in this catalogue have the same setup:



This modular concept makes Comato very versatile and economic: With a small assortment you can assemble a wide range of tools for many applications:

- Large cutting depths
- High precision
- Side turning/finish turning/contouring
- Very large range of groove dimensions, see inside front cover
- Special Comato grinding service offers fast delivery of special profiles in Comato quality

TOOL SYSTEM FEATURES AND BENEFITS

All Comato systems have principally the same design, consisting of toolholder, insert, clamp and support blade. This set-up gives the user large possibilities in different applications as parting-off, side turning, face-grooving and threading in a wide range of groove widths, depths and diameters with the same toolholder, by only changing clamp, support blade and insert.

This makes Comato the most versatile and economic system available on the market.

EXAMPLE ONE, GROOVING

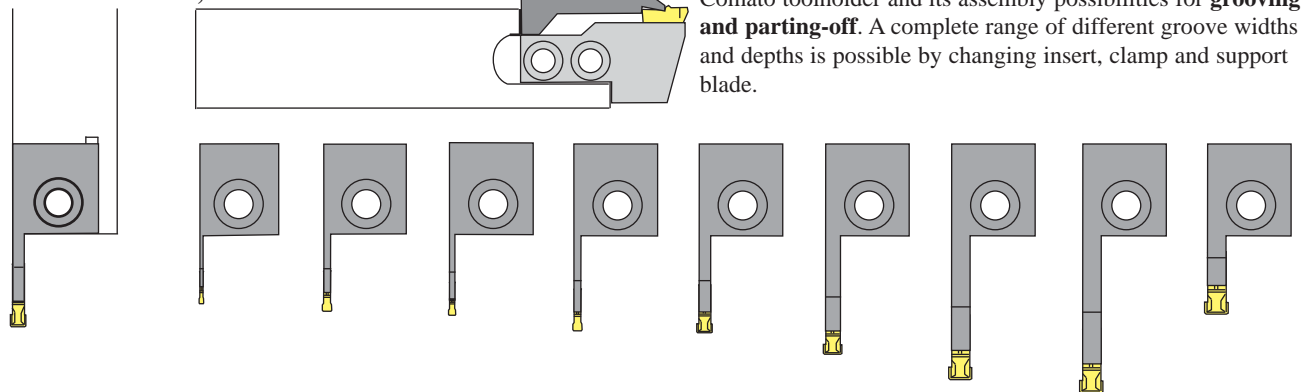

EXAMPLE TWO, FACE GROOVING

Comato toolholder and its assembly possibilities for face grooving with one insert. A complete range of different groove diameters is possible by changing only clamp and support blade.

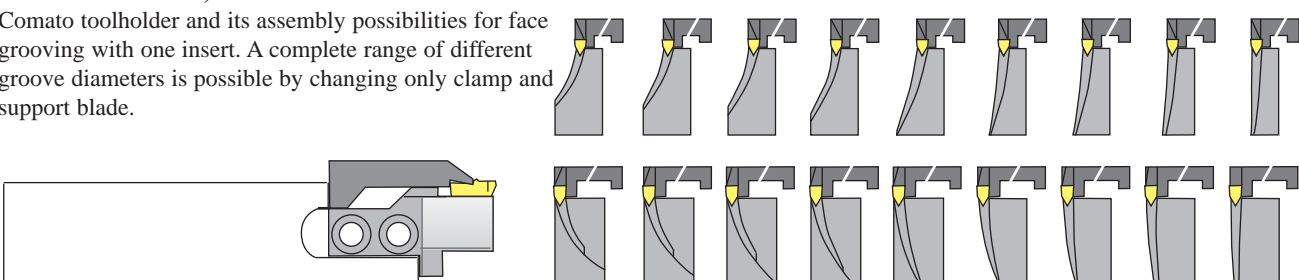

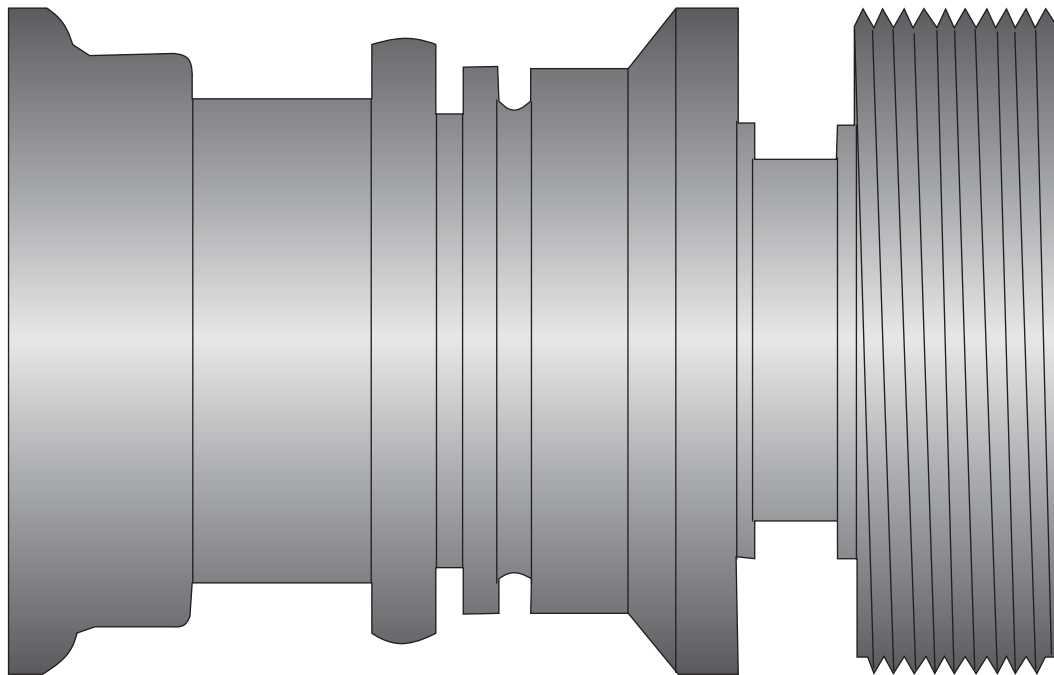

EXTERNAL GROOVING APPLICATIONS

- grooving
- side turning
- profiling
- contouring
- parting-off
- threading
- circlips
- radius grooves
- special profiles

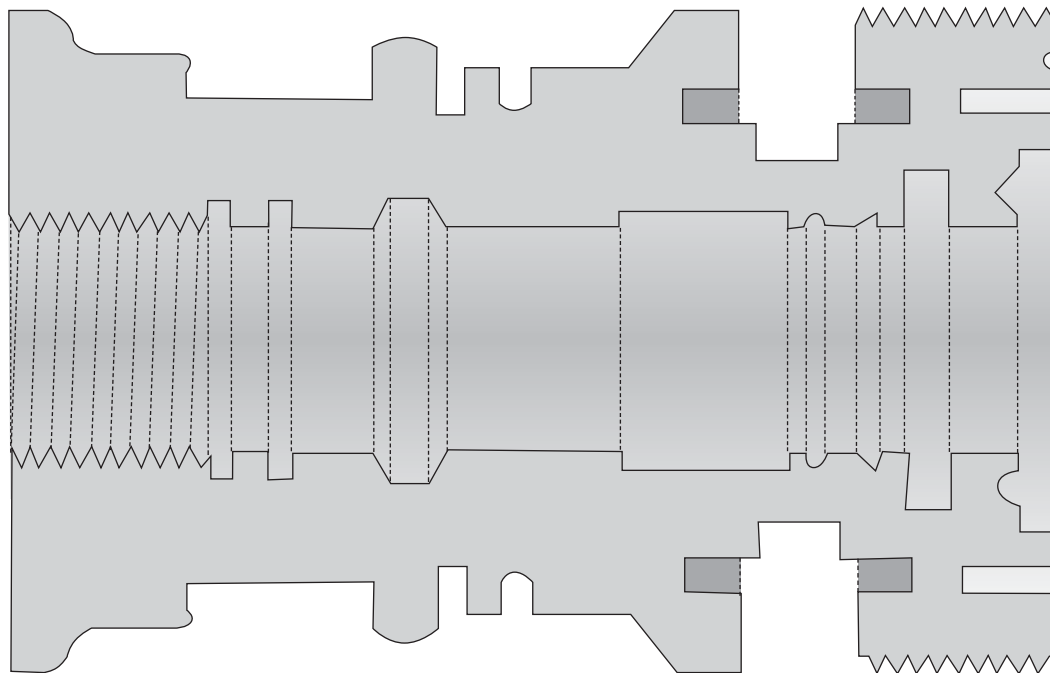

FACE GROOVING & INTERNAL GROOVING APPLICATIONS

- grooving
- side turning
- profiling
- threading
- circlips
- radius grooves
- special profiles

Comato[®] special profiles

Comato can offer you a special grinding service, this means for you:

- * short delivery time
- * special profiles in Comato quality

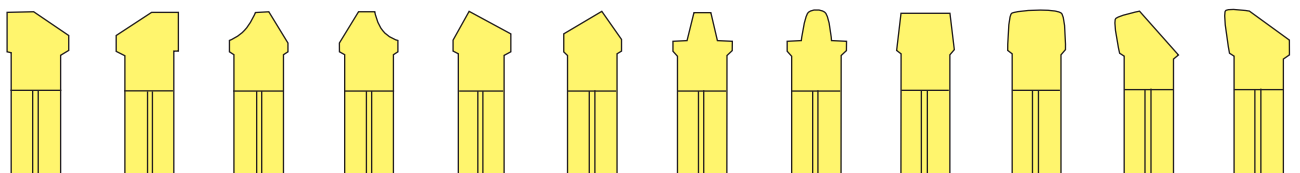

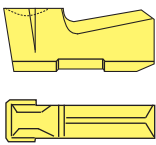
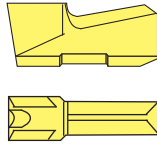
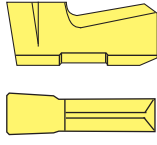
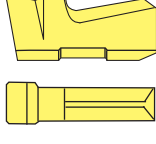
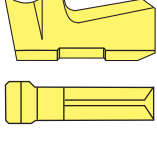
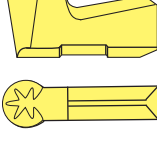
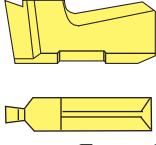
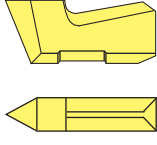
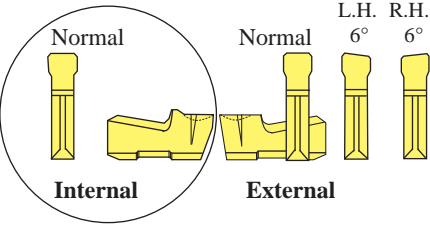

COMATO® GEOMETRIES

 <p>Type 150. for most grooving and parting-off operations.</p> <p style="text-align: right;">Page</p> <p>External : 150 6 Internal : 150 N 12 External : 150 6R/6L 6</p>	 <p>Type 150.GT. for grooving, parting-off and side turning.</p> <p style="text-align: right;">Page</p> <p>External : 150 GT 7 Internal : 150 GTN 12</p>	 <p>Type 150.0. with 0° rake angle, also suitable for special profiles.</p> <p style="text-align: right;">Page</p> <p>External : 150 0 7 Internal : 150 0N 12</p>
 <p>Type 150.10. with 10° rake, for stainless steel, etc.</p> <p style="text-align: right;">Page</p> <p>External : 150 10 8 Internal : 150 10 N 13 External : 150 10 6R/6L 8</p>	 <p>Type 150.25. with 25° rake angle for aluminium, copper etc.</p> <p style="text-align: right;">Page</p> <p>External : 150 25 9 Internal : 150 25N 13 External : 150 25 6R/6L 9</p>	 <p>Type 150.RD. for contour turning, relief grooves and full radius grooves.</p> <p style="text-align: right;">Page</p> <p>External : 150 RD 7 Internal : 150 RDN 13</p>
 <p>Type 150.CE/CN. for external or internal circlips acc. DIN 471 and DIN 472.</p> <p style="text-align: right;">Page</p> <p>External : 150 CE 10 Internal : 150 CN 10 * In- External : 150 CE/NK 11 * <i>With chamfrain</i></p>	 <p>Type 150.55/60. for external threading, partial profile 55° or 60°.</p> <p style="text-align: right;">Page</p> <p>in- and external : 150 55 10 in- and external : 150 60 10</p>	<p>INSERT EXECUTIONS</p>  <p>Normal L.H. R.H. 6° 6°</p> <p>Internal External</p>

COMATO® CARBIDE GRADES		Wear resistance Toughness					Wear resistance Toughness				
		ISO P					ISO K				
		05	10	20	30	40	05	10	20	30	40
P30F - P30C	Very suitable as allround grade due to the tough substrate and the wear-resistant coating. The special coating reduces loose-edge buildup and is especially fit for machining martensitic and austenitic stainless steels.				P30F/C						
K10F - K10C	This is a general grade for malleable, nodular and grey cast iron and high temperature, high strength alloys. K10C has a titanium carbide coating over a substrate with excellent abrasion resistance and high toughness.						K10F/C				
P30	This grade is intended for severe applications at relatively low cutting speeds on plain carbon, alloys, steels and stainless steels. P30 has excellent resistance to breakage and thermo-mechanical shock.				P30						
K10	A grade particular suitable for grooving operations on nodular, malleable and grey cast iron and high temperature alloys. K10 has excellent abrasion resistance, good toughness and is very good resistance to thermal shock.						K10				
CBN	For hardened steels, HSS, Cast Iron, Incoloy, Waspoly, Colmonoy, Inconel, Rene 42/77 Grinding will be fully replaced by turning						CBN				
PKD	For all your non ferrous materials, like Aluminium, Copper, Brass. Messing. Sintered and non-sintered Carbide. Magnesium bound materials and Ceramics. Grinding will be fully replaced by turning.						PKD				
C20	A Cermet-grade for grooving and parting-off. Can be used very successfully where loose-edge build up is a problem, even at very low cutting speeds.	C20									

RECOMMENDATIONS FOR PARTING-OFF											
Material	Recommended carbide grade	Feed mm				Alternative carbide grade	Feed mm				
		0,05	0,1	0,2	0,4		0,05	0,1	0,2	0,4	
		cutting speed m/min						cutting speed m/min			
Low carbon steel	P30C	160	130	110	110	P30		120	100	75	
Carbon steel	P30F	200	170	140		P30		110	90	65	
Alloyed steel	P30C		140	100	90	P30		100	90	70	
Stainless steel	P30C		130	110	90	P30		90	80	70	
Cast steel	P30C		100	80	60	P30		70	65	45	
Heat resistant Iron-based alloys	K10C	125	80	75	50	K10		80	75	50	
Hard steel (Manganese steel)	K10		25	20							
Malleable Iron	K10F	160	160	135		K10	120	110	100		
Cast Iron	K10F	140	140	120		P30F		90	80	65	
Aluminium alloys	K10		300	250		PKD					
Heat resistant Nickel-based alloys	K10	35	25	15							
Heat resistant Cobalt-based alloys	K10	35	25	15							
Non-Ferrous materials	K10	300	200	150		PKD					

RECOMMENDATIONS FOR GROOVING											
Material	Recommended carbide grade	Feed mm				Alternative carbide grade	Feed mm				
		0,05	0,1	0,2	0,4		0,05	0,1	0,2	0,4	
		cutting speed m/min						cutting speed m/min			
Low carbon steel	P30C		180	130	110	P30	120	110	100	75	
Carbon steel	P30F	200	190	160	85	P30	165	150	125	70	
Alloyed steel	P30C	165	150	110		P30	110	100	90		
Stainless steel	P30C	155	140	100		P30	95	90	80	65	
Cast steel	P30C	115	95	80	60	P30	90	80	70	45	
Heat resistant Iron-based alloys	K10C	125	80	80	50	K10	85	80	80	50	
Hard steel (Manganese steel)	K10		30	25							
Malleable Iron	K10F	160	150	130	85	K10	120	100	100		
Cast Iron	K10F	155	135	120	85	P30F		75	70	50	
Aluminium alloys	K10	350	300	300	200	PKD					
Heat resistant Nickel-based alloys	K10	35	25	15							
Heat resistant Cobalt-based alloys	K10	35	25	15							
Non-Ferrous materials	K10	300	200	150	100	PKD					

RECOMMENDATIONS FOR FACE GROOVING	RECOMMENDATIONS FOR SIDE TURNING
<ul style="list-style-type: none"> - Cutting speed 80% of cutting speed for parting-off. - Feed 50% of feed for parting-off. - Apply sufficient cooling directly on cutting edge. - See also page 23. 	<ul style="list-style-type: none"> - Cutting speed same as cutting speed for grooving. - Feed from 0,1 mm. to 0,25 mm. - Cutting depth: min. 0,25 mm. max. 0,8 x cutting width of insert.

NOTE
The above data are for guidance only. Actual performance depends on various factors, such as mounting stability, workpiece shape and specific material characteristics.

INSERTS

FOR EXTERNAL GROOVING & INTERNAL GROOVING
ABOVE Ø 50 MM

TM
Comadex

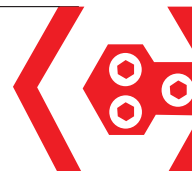

150

STANDARD INSERT WITH
CHIP-CONTROL

CW +0,1	Ordering code	H	L	r	Stock standard						Stock standard	
					P30TC	P30C	P30F	K10TC	K10C	K10F	P30	K10
2,0	150.2	3,6	9	0,3	<input type="checkbox"/>	<input checked="" type="checkbox"/>	<input checked="" type="checkbox"/>	<input type="checkbox"/>	<input type="checkbox"/>	<input type="checkbox"/>	<input checked="" type="checkbox"/>	<input checked="" type="checkbox"/>
2,5	150.2,5	3,6	9	0,3	<input type="checkbox"/>	<input checked="" type="checkbox"/>	<input checked="" type="checkbox"/>	<input type="checkbox"/>	<input type="checkbox"/>	<input type="checkbox"/>	<input checked="" type="checkbox"/>	<input checked="" type="checkbox"/>
3,0	150.3	6,0	14	0,3	<input type="checkbox"/>	<input checked="" type="checkbox"/>	<input checked="" type="checkbox"/>	<input type="checkbox"/>	<input type="checkbox"/>	<input type="checkbox"/>	<input checked="" type="checkbox"/>	<input checked="" type="checkbox"/>
4,0	150.4	6,0	14	0,3	<input type="checkbox"/>	<input checked="" type="checkbox"/>	<input checked="" type="checkbox"/>	<input type="checkbox"/>	<input type="checkbox"/>	<input type="checkbox"/>	<input checked="" type="checkbox"/>	<input checked="" type="checkbox"/>
5,0	150.5	6,0	14	0,3	<input type="checkbox"/>	<input checked="" type="checkbox"/>	<input checked="" type="checkbox"/>	<input type="checkbox"/>	<input type="checkbox"/>	<input type="checkbox"/>	<input checked="" type="checkbox"/>	<input checked="" type="checkbox"/>
6,0	150.6	6,0	14	0,3	<input type="checkbox"/>	<input checked="" type="checkbox"/>	<input checked="" type="checkbox"/>	<input type="checkbox"/>	<input type="checkbox"/>	<input type="checkbox"/>	<input checked="" type="checkbox"/>	<input checked="" type="checkbox"/>
8,0	150.8	6,0	14	0,3	<input type="checkbox"/>	<input checked="" type="checkbox"/>	<input checked="" type="checkbox"/>	<input type="checkbox"/>	<input type="checkbox"/>	<input type="checkbox"/>	<input checked="" type="checkbox"/>	<input checked="" type="checkbox"/>
10,0	150.10	7,5	16	0,3	<input type="checkbox"/>	<input checked="" type="checkbox"/>	<input checked="" type="checkbox"/>	<input type="checkbox"/>	<input type="checkbox"/>	<input type="checkbox"/>	<input checked="" type="checkbox"/>	<input checked="" type="checkbox"/>

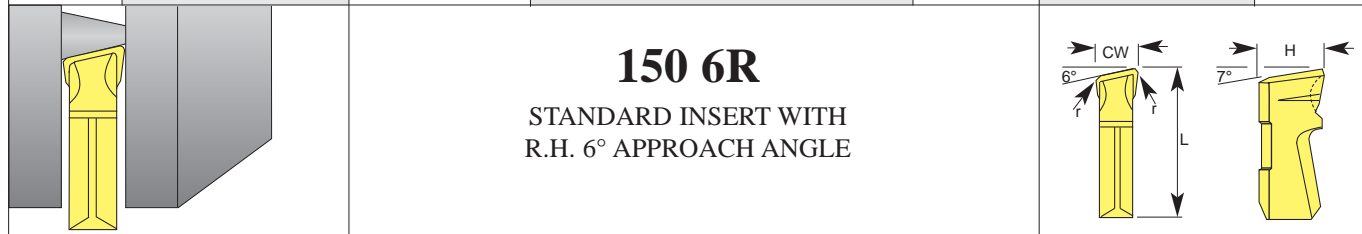

150 6R

STANDARD INSERT WITH
R.H. 6° APPROACH ANGLE

CW +0,1	Ordering code	H	L	r	Stock standard				Stock standard		
					P30TC	P30F	K10TC	K10F	P30	K10	CBN
1,8	150.2.6R	3,6	9	0,2	<input checked="" type="checkbox"/>	<input checked="" type="checkbox"/>	<input type="checkbox"/>	<input type="checkbox"/>	<input checked="" type="checkbox"/>	<input checked="" type="checkbox"/>	<input type="checkbox"/>
2,3	150.2,5.6R	3,6	9	0,2	<input checked="" type="checkbox"/>	<input checked="" type="checkbox"/>	<input type="checkbox"/>	<input type="checkbox"/>	<input checked="" type="checkbox"/>	<input checked="" type="checkbox"/>	<input type="checkbox"/>
2,8	150.3.6R	6,0	14	0,2	<input checked="" type="checkbox"/>	<input checked="" type="checkbox"/>	<input type="checkbox"/>	<input type="checkbox"/>	<input checked="" type="checkbox"/>	<input checked="" type="checkbox"/>	<input type="checkbox"/>
3,8	150.4.6R	6,0	14	0,2	<input checked="" type="checkbox"/>	<input checked="" type="checkbox"/>	<input type="checkbox"/>	<input type="checkbox"/>	<input checked="" type="checkbox"/>	<input checked="" type="checkbox"/>	<input type="checkbox"/>
4,8	150.5.6R	6,0	14	0,2	<input checked="" type="checkbox"/>	<input checked="" type="checkbox"/>	<input type="checkbox"/>	<input type="checkbox"/>	<input checked="" type="checkbox"/>	<input checked="" type="checkbox"/>	<input type="checkbox"/>
5,8	150.6.6R	6,0	14	0,2	<input checked="" type="checkbox"/>	<input checked="" type="checkbox"/>	<input type="checkbox"/>	<input type="checkbox"/>	<input checked="" type="checkbox"/>	<input checked="" type="checkbox"/>	<input type="checkbox"/>
7,8	150.8.6R	6,0	14	0,2	<input type="checkbox"/>	<input type="checkbox"/>	<input type="checkbox"/>	<input type="checkbox"/>	<input type="checkbox"/>	<input type="checkbox"/>	<input type="checkbox"/>
9,8	150.10.6R	7,5	16	0,2	<input type="checkbox"/>	<input type="checkbox"/>	<input type="checkbox"/>	<input type="checkbox"/>	<input type="checkbox"/>	<input type="checkbox"/>	<input type="checkbox"/>

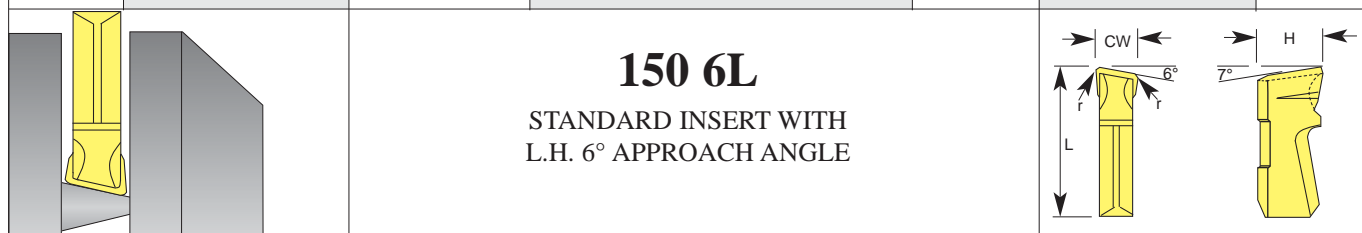

150 6L

STANDARD INSERT WITH
L.H. 6° APPROACH ANGLE

CW +0,1	Ordering code	H	L	r	Stock standard				Stock standard		
					P30TC	P30F	K10TC	K10F	P30	K10	CBN
1,8	150.2.6L	3,6	9	0,2	<input checked="" type="checkbox"/>	<input checked="" type="checkbox"/>	<input type="checkbox"/>	<input type="checkbox"/>	<input checked="" type="checkbox"/>	<input checked="" type="checkbox"/>	<input type="checkbox"/>
2,3	150.2,5.6L	3,6	9	0,2	<input checked="" type="checkbox"/>	<input checked="" type="checkbox"/>	<input type="checkbox"/>	<input type="checkbox"/>	<input checked="" type="checkbox"/>	<input checked="" type="checkbox"/>	<input type="checkbox"/>
2,8	150.3.6L	6,0	14	0,2	<input checked="" type="checkbox"/>	<input checked="" type="checkbox"/>	<input type="checkbox"/>	<input type="checkbox"/>	<input checked="" type="checkbox"/>	<input checked="" type="checkbox"/>	<input type="checkbox"/>
3,8	150.4.6L	6,0	14	0,2	<input checked="" type="checkbox"/>	<input checked="" type="checkbox"/>	<input type="checkbox"/>	<input type="checkbox"/>	<input checked="" type="checkbox"/>	<input checked="" type="checkbox"/>	<input type="checkbox"/>
4,8	150.5.6L	6,0	14	0,2	<input checked="" type="checkbox"/>	<input checked="" type="checkbox"/>	<input type="checkbox"/>	<input type="checkbox"/>	<input checked="" type="checkbox"/>	<input checked="" type="checkbox"/>	<input type="checkbox"/>
5,8	150.6.6L	6,0	14	0,2	<input checked="" type="checkbox"/>	<input checked="" type="checkbox"/>	<input type="checkbox"/>	<input type="checkbox"/>	<input checked="" type="checkbox"/>	<input checked="" type="checkbox"/>	<input type="checkbox"/>
7,8	150.8.6L	6,0	14	0,2	<input type="checkbox"/>	<input type="checkbox"/>	<input type="checkbox"/>	<input type="checkbox"/>	<input type="checkbox"/>	<input type="checkbox"/>	<input type="checkbox"/>
9,8	150.10.6L	7,5	16	0,2	<input type="checkbox"/>	<input type="checkbox"/>	<input type="checkbox"/>	<input type="checkbox"/>	<input type="checkbox"/>	<input type="checkbox"/>	<input type="checkbox"/>

		150 GT GROOVING AND SIDE TURNING INSERT											
CW +0,1	Ordering code	H	L	r	Stock standard			Stock standard					
				-0,1	P30TC	P30C	P30F	K10TC	K10C	K10F	P30	K10	
3,0	150.3.GT	6,0	14	0,3	■	■			□	□	■	□	
4,0	150.4.GT	6,0	14	0,3	■	■			□	□	■	□	
5,0	150.5.GT	6,0	14	0,3	■	■			□	□	■	□	
6,0	150.6.GT	6,0	14	0,3	■	■			□	□	■	□	
8,0	150.8.GT	6,0	14	0,3	■	■			□	□	■	□	
10,0	150.10.GT	7,5	16	0,3	■	■			□	□	■	□	
		150 0 STANDARD INSERT (BLANK) WITH 0° RAKE ANGLE											
					Stock standard			Stock standard					
CW +0,1	Ordering code	H	L	r	P30TC	P30F	K10TC	K10C	K10F	P30	K10	CBN	
2,0	150.2.0	3,6	9	0,3	□	□	□	□	□	■	■	□	
2,5	150.2,5.0	3,6	9	0,3	□	□	□	□	□	■	■	□	
3,0	150.3.0	6,0	14	0,3	□	□	□	□	□	■	■	□	
4,0	150.4.0	6,0	14	0,3	□	□	□	□	□	■	■	□	
5,0	150.5.0	6,0	14	0,3	□	□	□	□	□	■	■	□	
6,0	150.6.0	6,0	14	0,3	□	□	□	□	□	■	■	□	
8,0	150.8.0	6,0	14	0,3	□	□	□	□	□	■	■	□	
10,0	150.10.0	7,5	16	0,3	□	□	□	□	□	■	■	□	
		150 RD RADIUS INSERT											
					Stock standard			Stock standard					
CW +0,1	Ordering code	H	L	R	P30TC	P30C	P30F	K10TC	K10C	K10F	P30	K10	CBN
1,8	150.2.RD	3,6	9	0,9	□			□	□	□	■	□	□
2,3	150.2,5.RD	3,6	9	1,15	□			□	□	□	■	□	□
2,7	150.3.RD	6,0	14	1,35	□	■	■	□	□	□	■	■	□
4,0	150.4.RD	6,0	14	2,0	□	■	■	□	□	□	■	■	□
4,6	150.5.RD	6,0	14	2,3	■		■	□	□	□	■	■	□
5,6	150.6.RD	6,0	14	2,8	■		■	□	□	□	■	■	□
7,6	150.8.RD	6,0	14	3,8	■		■	□	□	□	■	■	□
9,5	150.10.RD	7,5	16	4,75	■		■	□	□	□	■	■	□

INSERTS

FOR EXTERNAL GROOVING & INTERNAL GROOVING
ABOVE Ø 50 MM

TM
Comadex

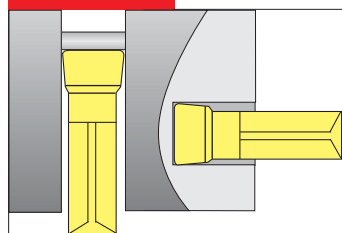
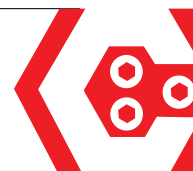

150 10

STANDARD INSERT WITH 10°
RAKE ANGLE

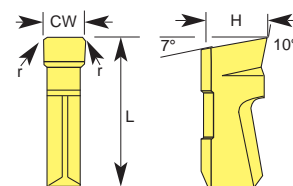

CW +0,1	Ordering code	H	L	r	Stock standard				Stock standard		
					P30TC	P30F	K10TC	K10F	P30	K10	PCD
2,0	150.2.10	3,6	9	0,3	■	■	□	□	■	■	□
2,5	150.2,5.10	3,6	9	0,3	■	■	□	□	■	■	□
3,0	150.3.10	6,0	14	0,3	■	■	□	□	■	■	□
4,0	150.4.10	6,0	14	0,3	■	■	□	□	■	■	□
5,0	150.5.10	6,0	14	0,3	■	■	□	□	■	■	□
6,0	150.6.10	6,0	14	0,3	□	□	□	□	■	■	□
8,0	150.8.10	6,0	14	0,3	□	□	□	□	□	□	□
10,0	150.10.10	7,0	16	0,3	□	□	□	□	□	□	□

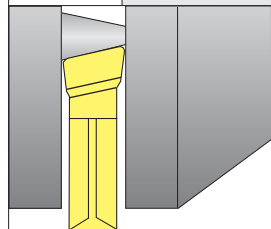

150 10 6R

STANDARD INSERT WITH 10° RAKE ANGLE
AND R.H. 6° APPROACH ANGLE

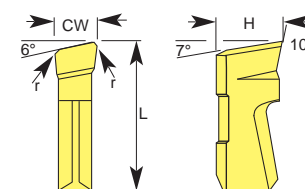
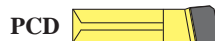

CW +0,1	Ordering code	H	L	r	Stock standard				Stock standard		
					P30TC	P30F	K10TC	K10F	P30	K10	PCD
1,8	150.2.10.6R	3,6	9	0,2	■	■	□	□	■	□	□
2,3	150.2,5.10.6R	3,6	9	0,2	■	■	□	□	■	□	□
2,8	150.3.10.6R	6,0	14	0,2	■	■	□	□	■	□	□
3,8	150.4.10.6R	6,0	14	0,2	■	■	□	□	■	□	□
4,8	150.5.10.6R	6,0	14	0,2	■	■	□	□	■	□	□
5,8	150.6.10.6R	6,0	14	0,2	□	□	□	□	■	□	□
7,8	150.8.10.6R	6,0	14	0,2	□	□	□	□	□	□	□
9,8	150.10.10.6R	7,0	16	0,2	□	□	□	□	□	□	□

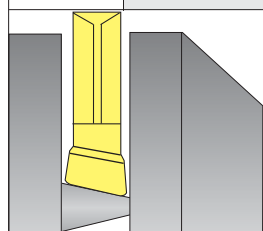

150 10 6L

STANDARD INSERT WITH 10° RAKE ANGLE
AND L.H. 6° APPROACH ANGLE

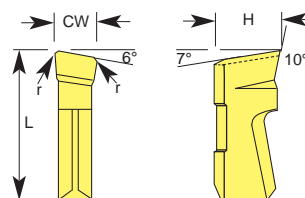

CW +0,1	Ordering code	H	L	r	Stock standard				Stock standard		
					P30TC	P30F	K10TC	K10F	P30	K10	PCD
1,8	150.2.10.6L	3,6	9	0,2	■	■	□	□	■	□	□
2,3	150.2,5.10.6L	3,6	9	0,2	■	■	□	□	■	□	□
2,8	150.3.10.6L	6,0	14	0,2	■	■	□	□	■	□	□
3,8	150.4.10.6L	6,0	14	0,2	■	■	□	□	■	□	□
4,8	150.5.10.6L	6,0	14	0,2	■	■	□	□	■	□	□
5,8	150.6.10.6L	6,0	14	0,2	□	□	□	□	■	□	□
7,8	150.8.10.6L	6,0	14	0,2	□	□	□	□	□	□	□
9,8	150.10.10.6L	7,0	16	0,2	□	□	□	□	□	□	□

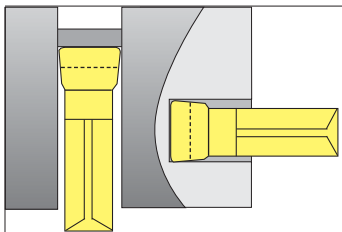
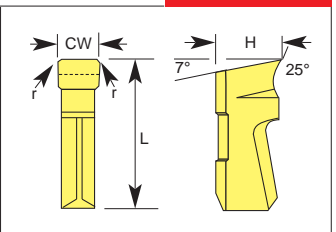
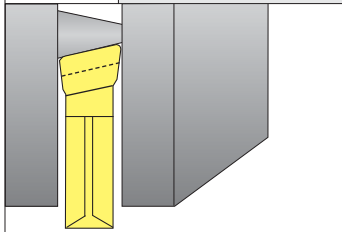
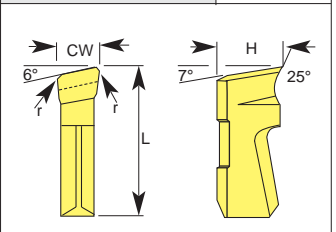
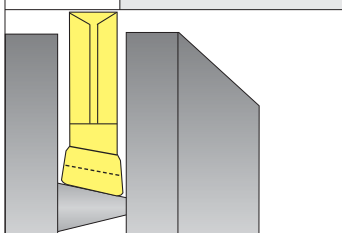
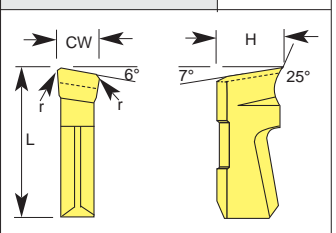
		<h3>150 25</h3> <p>HIGH-POSITIVE-RAKE INSERT 25° FOR ALUMINIUM ETC.</p>								
CW +0,1	Ordering code	H	L	r	Stock standard				Stock standard	
					P30TC	P30F	K10TC	K10F	P30	K10
2,0	150.2.25	3,6	9	0,3					■	
2,5	150.2.5.25	3,6	9	0,3					■	
3,0	150.3.25	6,0	14	0,3	■	■			■	
4,0	150.4.25	6,0	14	0,3	■	■			■	
5,0	150.5.25	6,0	14	0,3	■	■			■	
6,0	150.6.25	6,0	14	0,3	■	■			■	
8,0	150.8.25	6,0	14	0,3	■	■			□	
10,0	150.10.25	7,0	16	0,3					□	
		<h3>150 25 6R</h3> <p>HIGH-POSITIVE-RAKE INSERT 25° WITH R.H. 6° APPROACH ANGLE</p>								
CW +0,1	Ordering code	H	L	r	Stock standard				Stock standard	
					P30TC	P30F	K10TC	K10F	P30	K10
1,8	150.2.25.6R	3,6	9	0,2					■	
2,3	150.2.5.25.6R	3,6	9	0,2					■	
2,8	150.3.25.6R	6,0	14	0,2					■	
3,8	150.4.25.6R	6,0	14	0,2					■	
4,8	150.5.25.6R	6,0	14	0,2					■	
5,8	150.6.25.6R	6,0	14	0,2					■	
7,8	150.8.25.6R	6,0	14	0,2					□	
9,8	150.10.25.6R	7,0	16	0,2					□	
		<h3>150 25 6L</h3> <p>HIGH-POSITIVE-RAKE INSERT 25° WITH L.H. 6° APPROACH ANGLE</p>								
CW +0,1	Ordering code	H	L	r	Stock standard				Stock standard	
					P30TC	P30F	K10TC	K10F	P30	K10
1,8	150.2.25.6L	3,6	9	0,2					■	
2,3	150.2.5.25.6L	3,6	9	0,2					■	
2,8	150.3.25.6L	6,0	14	0,2					■	
3,8	150.4.25.6L	6,0	14	0,2					■	
4,8	150.5.25.6L	6,0	14	0,2					■	
5,8	150.6.25.6L	6,0	14	0,2					■	
7,8	150.8.25.6L	6,0	14	0,2					□	
9,8	150.10.25.6L	7,0	16	0,2					□	

THREADING INSERTS

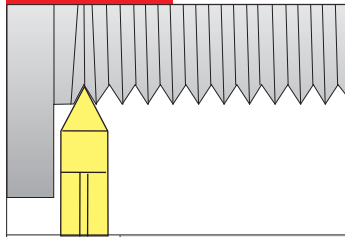

150 55 / 150 60
THREADING INSERTS 55° / 60°

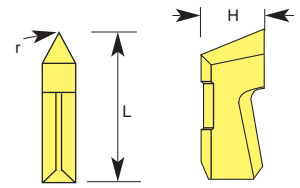

Pitch	Ordering code	H -0,1	L	r	Stock standard				Stock standard	
					P30TC	P30F	K10TC	K10F	P30	K10
48 - 12	150.2,5.55	3,6	9	0,07					<input type="checkbox"/>	<input type="checkbox"/>
0,5 - 2,0	150.2,5.60	3,6	9	0,07					<input type="checkbox"/>	<input type="checkbox"/>
11 - 5	150.4.55	6,0	14	0,20	<input type="checkbox"/>	<input type="checkbox"/>			<input type="checkbox"/>	<input type="checkbox"/>
2,5 - 5,0	150.4.60	6,0	14	0,20	<input type="checkbox"/>	<input type="checkbox"/>			<input checked="" type="checkbox"/>	<input checked="" type="checkbox"/>

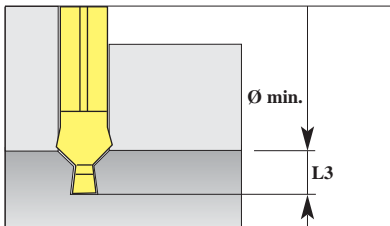
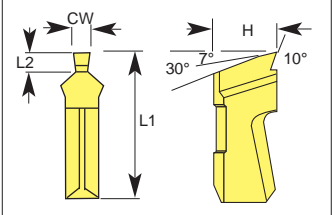
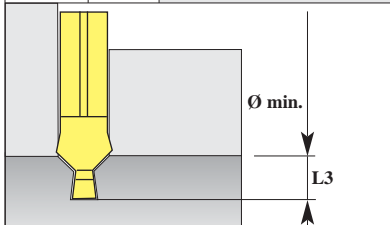
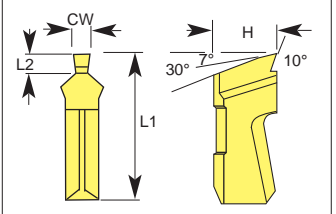
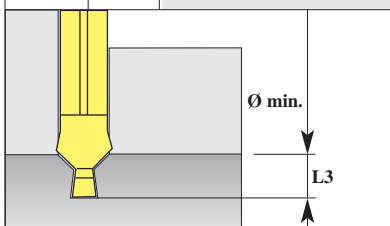
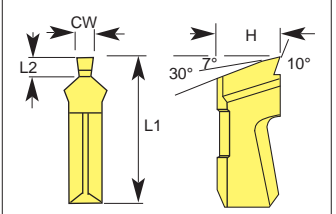
			<h3>150 CE/NK</h3> <p>INSERT WITH 10° RAKE ANGLE FOR INTERNAL & EXTERNAL WITH CHAMFRAINING LOCKING RINGS (CIRCLIPS)</p>										
Circlip	CW +0,05	Ordering code	H	L1	L2	L3	Ø-Ø	Stock standard		Stock standard			
								P30TC	P30F	K10TC	K10F	P30	K10
1,0	1,10	150.1,1.CE/NK-11	3,6	8,8	0,22	0,25	11-12	<input type="checkbox"/>	<input type="checkbox"/>			<input checked="" type="checkbox"/>	<input checked="" type="checkbox"/>
1,0	1,10	150.1,1.CE/NK-13	3,6	8,8	0,27	0,30	13-14	<input type="checkbox"/>	<input type="checkbox"/>			<input checked="" type="checkbox"/>	<input checked="" type="checkbox"/>
1,0	1,10	150.1,1.CE/NK-15	3,6	8,8	0,32	0,35	15-/-	<input type="checkbox"/>	<input type="checkbox"/>			<input checked="" type="checkbox"/>	<input checked="" type="checkbox"/>
1,0	1,10	150.1,1.CE/NK-16	3,6	8,8	0,37	0,40	16-17	<input type="checkbox"/>	<input type="checkbox"/>			<input checked="" type="checkbox"/>	<input checked="" type="checkbox"/>
			<h3>150 CE/NK</h3> <p>INSERT WITH 10° RAKE ANGLE FOR INTERNAL & EXTERNAL WITH CHAMFRAINING LOCKING RINGS (CIRCLIPS)</p>										
Circlip	CW +0,05	Ordering code	H	L1	L2	L3	Ø-Ø	Stock standard		Stock standard			
								P30TC	P30F	K10TC	K10F	P30	K10
1,2	1,30	150.1,3.CE/NK-18	3,6	8,8	0,45	0,50	18-22	<input type="checkbox"/>	<input type="checkbox"/>			<input checked="" type="checkbox"/>	<input checked="" type="checkbox"/>
1,2	1,30	150.1,3.CE/NK-24	3,6	8,8	0,50	0,55	24-26	<input type="checkbox"/>	<input type="checkbox"/>			<input checked="" type="checkbox"/>	<input checked="" type="checkbox"/>
1,5	1,60	150.1,6.CE/NK-28	3,6	8,8	0,64	0,70	28-30	<input type="checkbox"/>	<input type="checkbox"/>			<input checked="" type="checkbox"/>	<input checked="" type="checkbox"/>
1,5	1,60	150.1,6.CE/NK-32	3,6	8,8	0,79	0,85	32-34	<input type="checkbox"/>	<input type="checkbox"/>			<input checked="" type="checkbox"/>	<input checked="" type="checkbox"/>
1,5	1,60	150.1,6.CE/NK-35	3,6	8,8	0,94	1,00	35-/-	<input type="checkbox"/>	<input type="checkbox"/>			<input checked="" type="checkbox"/>	<input checked="" type="checkbox"/>
1,75	1,85	150.1,85.CE/NK-36	3,6	8,8	0,94	1,00	36-38	<input type="checkbox"/>	<input type="checkbox"/>			<input checked="" type="checkbox"/>	<input checked="" type="checkbox"/>
1,75	1,85	150.1,85.CE/NK-40	3,6	8,8	1,18	1,25	40-48	<input type="checkbox"/>	<input type="checkbox"/>			<input checked="" type="checkbox"/>	<input checked="" type="checkbox"/>
			<h3>150 CE/NK</h3> <p>INSERT WITH 10° RAKE ANGLE FOR INTERNAL & EXTERNAL WITH CHAMFRAINING LOCKING RINGS (CIRCLIPS)</p>										
Circlip	CW +0,05	Ordering code	H	L1	L2	L3	Ø-Ø	Stock standard		Stock standard			
								P30TC	P30F	K10TC	K10F	P30	K10
2,00	2,15	150K.2,15.CE/NK-50	3,6	8,8	1,40	1,50	50-63	<input type="checkbox"/>	<input type="checkbox"/>			<input checked="" type="checkbox"/>	<input checked="" type="checkbox"/>
2,00	2,15	150G.2,15.CE/NK-50	6,0	13,9	1,40	1,50	50-63	<input type="checkbox"/>	<input type="checkbox"/>			<input checked="" type="checkbox"/>	<input checked="" type="checkbox"/>
2,50	2,65	150.2,65.CE/NK-65	6,0	13,9	1,40	1,50	65-78	<input type="checkbox"/>	<input type="checkbox"/>			<input checked="" type="checkbox"/>	<input checked="" type="checkbox"/>
2,50	2,65	150.2,65.CE/NK-80	6,0	13,9	1,65	1,75	80-82	<input type="checkbox"/>	<input type="checkbox"/>			<input checked="" type="checkbox"/>	<input checked="" type="checkbox"/>
3,00	3,15	150.3,15.CE/NK-85	6,0	13,9	1,65	1,75	85-100	<input type="checkbox"/>	<input type="checkbox"/>			<input checked="" type="checkbox"/>	<input checked="" type="checkbox"/>
4,00	4,15	150.4,15.CE/NK-105	6,0	13,9	1,85	2,00	105-145	<input type="checkbox"/>	<input type="checkbox"/>			<input checked="" type="checkbox"/>	<input checked="" type="checkbox"/>
4,00	4,15	150.4,15.CE/NK-150	6,0	13,9	2,35	2,50	150-200	<input type="checkbox"/>	<input type="checkbox"/>			<input checked="" type="checkbox"/>	<input checked="" type="checkbox"/>
5,00	5,20	150.5,20.CE/NK-205	6,0	13,9	2,80	3,00	205-250	<input type="checkbox"/>	<input type="checkbox"/>			<input type="checkbox"/>	<input type="checkbox"/>
5,00	5,20	150.5,20.CE/NK-255	6,0	13,9	3,80	4,00	255-300	<input type="checkbox"/>	<input type="checkbox"/>			<input type="checkbox"/>	<input type="checkbox"/>

INSERTS

FOR INTERNAL GROOVING FROM Ø10 - Ø50 MM.

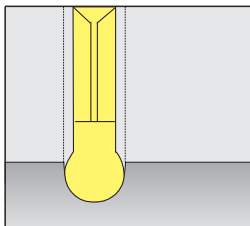
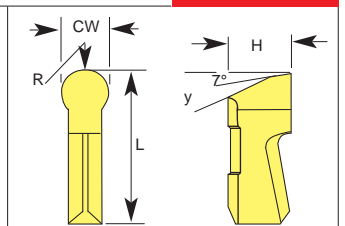

CW +0,1		Ø min.	Ordering code	H L r y -0,2	Stock standard				Stock standard			
CW +0,1		Ø min.	Ordering code	H L r y -0,2	P30TC	P30F	K10TC	K10F	P30	K10	CBN	
				<h2>150 N</h2> <p>STANDARD INSERT WITH CHIP-CONTROL</p>								
2,0	10	150.2.N.10	3,6 9 0,3 30°	■	■	□	□	■	■			
2,5	10	150.2,5.N.10	3,6 9 0,3 30°	■	■	□	□	■	■			
2,0	16	150.2.N.25	3,6 9 0,3 20°	■	■	□	□	■	■			
2,5	16	150.2,5.N.25	3,6 9 0,3 20°	■	■	□	□	■	■			
3,0	32	150.3.N.25	6,0 14 0,3 20°	□	□	□	□	□	□			
4,0	32	150.4.N.25	6,0 14 0,3 20°	□	□	□	□	□	□			
				<h2>150 GTN</h2> <p>GROOVING AND SIDE TURNING INSERT</p> <p>* Only for C25 holders</p>								
3,0	32	150.3.GTN	6,0 14 0,3 20°	■	■			□				
4,0	32	150.4.GTN	6,0 14 0,3 20°	■	■			□				
				<h2>150 0N</h2> <p>STANDARD INSERT WITH 0° RAKE ANGLE</p> <p style="text-align: right;">CBN </p>								
2,0	10	150.2.0N.10	3,6 9 0,3 30°	□	□	□	□	■	■			
2,5	10	150.2,5.0N.10	3,6 9 0,3 30°	□	□	□	□	■	■			
2,0	16	150.2.0N.25	3,6 9 0,3 20°	□	□	□	□	■	■			
2,5	16	150.2,5.0N.25	3,6 9 0,3 20°	□	□	□	□	■	■			
3,0	32	150.3.0N.25	6,0 14 0,3 20°	□	□	□	□	■	■			
4,0	32	150.4.0N.25	6,0 14 0,3 20°	□	□	□	□	■	■			

			<h3>150 RDN</h3> <p>RADIUS INSERT</p>										
CW +0,1	Ø min.	Ordering code	H	L	R	y	Stock standard				Stock standard		
			-0,2	-0,05			P30TC	P30F	K10TC	K10F	P30	K10	CBN
1,8	10	150.2.RDN.10	3,6	9	0,9	30°	■	■	<input type="checkbox"/>	<input type="checkbox"/>	■	■	<input type="checkbox"/>
2,3	10	150.2,5.RDN.10	3,6	9	1,15	30°	■	■	<input type="checkbox"/>	<input type="checkbox"/>	■	■	<input type="checkbox"/>
1,8	16	150.2.RDN.25	3,6	9	0,9	20°	■	■	<input type="checkbox"/>	<input type="checkbox"/>	■	■	<input type="checkbox"/>
2,3	16	150.2,5.RDN.25	3,6	9	1,15	20°	■	■	<input type="checkbox"/>	<input type="checkbox"/>	■	■	<input type="checkbox"/>
2,7	32	150.3.RDN.25	6,0	14	1,35	20°	<input type="checkbox"/>	<input type="checkbox"/>	<input type="checkbox"/>	<input type="checkbox"/>	<input type="checkbox"/>	<input type="checkbox"/>	<input type="checkbox"/>
3,8	32	150.4.RDN.25	6,0	14	1,9	20°	<input type="checkbox"/>	<input type="checkbox"/>	<input type="checkbox"/>	<input type="checkbox"/>	<input type="checkbox"/>	<input type="checkbox"/>	<input type="checkbox"/>

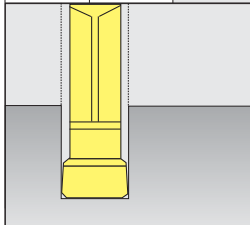
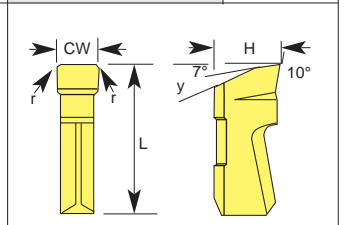
			<h3>150 10N</h3> <p>STANDARD INSERT WITH 10° RAKE ANGLE</p>										
CW +0,1	Ø min.	Ordering code	H	L	r	y	Stock standard				Stock standard		
			-0,1				P30TC	P30F	K10TC	K10F	P30	K10	PCD
2,0	10	150.2.10N.10	3,6	9	0,3	30°	■	■	<input type="checkbox"/>	<input type="checkbox"/>	■	<input type="checkbox"/>	<input type="checkbox"/>
2,5	10	150.2,5.10N.10	3,6	9	0,3	30°	■	■	<input type="checkbox"/>	<input type="checkbox"/>	■	<input type="checkbox"/>	<input type="checkbox"/>
2,0	16	150.2.10N.25	3,6	9	0,3	20°	■	■	<input type="checkbox"/>	<input type="checkbox"/>	■	■	<input type="checkbox"/>
2,5	16	150.2,5.10N.25	3,6	9	0,3	20°	■	■	<input type="checkbox"/>	<input type="checkbox"/>	■	■	<input type="checkbox"/>
3,0	32	150.3.10N.25	6,0	14	0,3	20°	<input type="checkbox"/>	<input type="checkbox"/>	<input type="checkbox"/>	<input type="checkbox"/>	<input type="checkbox"/>	<input type="checkbox"/>	<input type="checkbox"/>
4,0	32	150.4.10N.25	6,0	14	0,3	20°	<input type="checkbox"/>	<input type="checkbox"/>	<input type="checkbox"/>	<input type="checkbox"/>	<input type="checkbox"/>	<input type="checkbox"/>	<input type="checkbox"/>

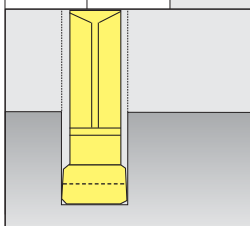
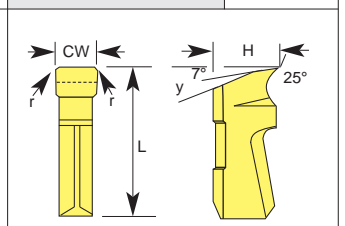
			<h3>150 25N</h3> <p>HIGH-POSITIVE-RAKE INSERT 25° FOR ALUMINIUM ETC.</p>									
CW +0,1	Ø min.	Ordering code	H	L	r	y	Stock standard				Stock standard	
			-0,1				P30TC	P30F	K10TC	K10F	P30	K10
2,0	10	150.2.25N.10	3,6	9	0,3	30°					■	
2,5	10	150.2,5.25N.10	3,6	9	0,3	30°					■	
2,0	16	150.2.25N.25	3,6	9	0,3	20°					■	
2,5	16	150.2,5.25N.25	3,6	9	0,3	20°					■	
3,0	32	150.3.25N.25	6,0	14	0,3	20°					<input type="checkbox"/>	
4,0	32	150.4.25N.25	6,0	14	0,3	20°					<input type="checkbox"/>	

MINI PARTING-OFF SYSTEM BASIC TOOLHOLDER

NOTE: Toolholders are supplied with screws for support blade and clamp only.
Clamps, support blades, keys and inserts must be ordered separately.

For inserts, see page 6 - 11.

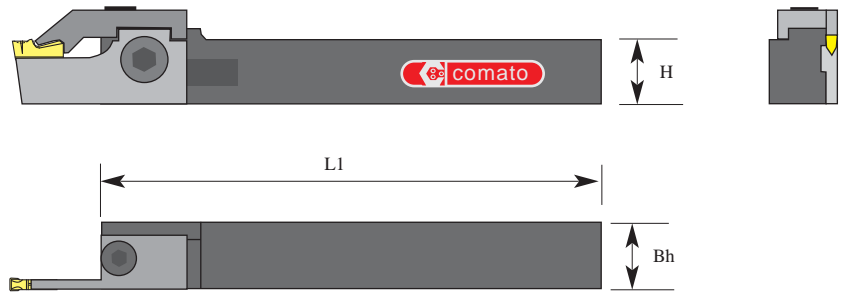

Dimensions			CW max.	CD max.	Ordering code R.H. Toolholder	Stock standard	Ordering code L.H. Toolholder	Stock standard
H	Bh	L1						
10	10	80	2,5	16	MPER 1010	■	MPEL 1010	■
12	12	90	2,5	16	MPER 1212	■	MPEL 1212	■

CW mm.		CD mm.	Ordering code R.H. support blade		Stock standard	Ordering code R.H. support blade		Stock standard	ordering code R.H. clamp		Stock standard
2	2,5		for MPER 1010	312-154201-10		for MPER 1212	312-154201-12		412-154201	416-154251	
2		12	for MPER 1010	312-154201-10	■	for MPER 1212	312-154201-12	■	412-154201	■	
2,5		16		316-154251-10	■		316-154251-12	■	416-154251	■	

CW mm.		CD mm.	Ordering code L.H. support blade		Stock standard	Ordering code L.H. support blade		Stock standard	ordering code L.H. clamp		Stock standard
2	2,5		for MPEL 1010	312-154202-10		for MPEL 1212	312-154202-12		412-154202	416-154252	
2		12	for MPEL 1010	312-154202-10	■	for MPEL 1212	312-154202-12	■	412-154202	■	
2,5		16		316-154252-10	■		316-154252-12	■	416-154252	■	

SPARE PARTS FOR THE ENTIRE MINI PARTING-OFF SYSTEM

ordering code	Description	Number per holder
M3x6MC Hex M2,5	Screw for clamp Key for clamp-screw	1
M4x10MK Hex M2,5	Screw for support blade Key for support blade screw	1

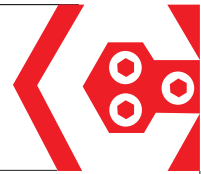

MINI SYSTEM BASIC TOOLHOLDER FOR RADIAL GROOVING AND FACE GROOVING

NOTE: Toolholders are supplied with screws for support blade and clamp only. Clamps, support blades, keys and inserts must be ordered separately.

For inserts, see page 6 - 11

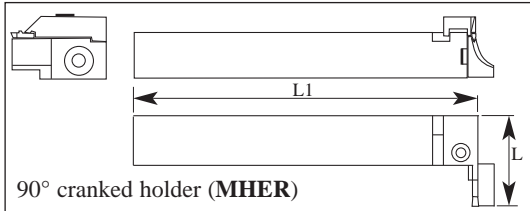
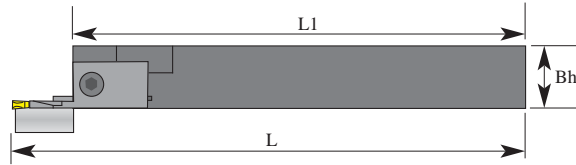

90° cranked holder (MHER)

MER holder shown

Dimensions		CW max.	CD max.	Ordering code R.H. toolholder	Stock standard	Ordering code L.H. toolholder	Stock-standard
H	Bh						
12	12	136	120	MER 1212	■	MEL 1212	■
16	16	136	120	MER 1616	■	MEL 1616	■
20	20	136	140	MER 2020	■	MEL 2020	■
25	25	136	140	MER 2525	■	MEL 2525	■
20	20	36	145	MHER 2020*	■	MHEL 2020*	■
25	25	36	145	MHER 2525*	■	MHEL 2525*	■

*=90° cranked shaft

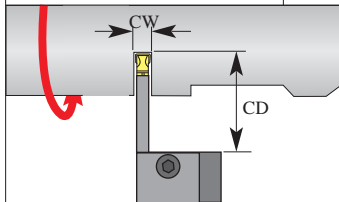

SUPPORT BLADES AND CLAMPS FOR RADIAL GROOVING AND PARTING-OFF FOR R.H. TOOLHOLDERS

SUPPORT BLADE



CLAMP



CW mm.	CD mm.	La mm.	Ordering code R.H. support blade	Stock standard	Ordering code R.H. clamp	Stock standard
2	16	36	316-155201	■	416-155201	■
2,5	16	36	316-155251	■	416-155251	■
2,5	20	40	320-155251	■	420-155251	■
3	20	40	320-155301	■	420-155301	■

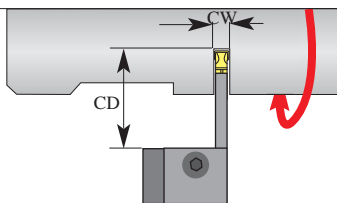

SUPPORT BLADES AND CLAMPS FOR RADIAL GROOVING AND PARTING-OFF FOR L.H. TOOLHOLDERS

SUPPORT BLADE

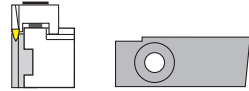

CLAMP



CW mm.	CD mm.	La mm.	Ordering code L.H. support blade	Stock standard	Ordering code L.H. clamp	Stock standard
2	16	36	316-155202	■	416-155202	■
2,5	16	36	316-155252	■	416-155252	■
2,5	20	40	320-155252	■	420-155252	■
3	20	40	320-155302	■	420-155302	■

SPARE PARTS FOR THE ENTIRE MINI SYSTEM

Ordering code	Description	Number per holder
M4x8MC Hex M3	Screw for clamp Key for clamp-screw	1
M5x12MK Hex M3	Screw for support blade Key for support blade-screw	1

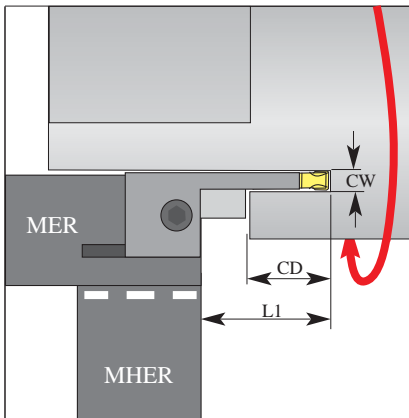

SUPPORT BLADES AND CLAMPS FOR
MINI FACE GROOVING:
R.H. TOOLHOLDERS / L.H. TURNING

SUPPORT BLADE

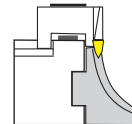
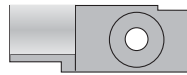

CLAMP

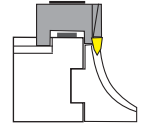

CW mm.	Outer-Ø* mm.	CD mm.	L1 mm.	Ordering code R.H. support blade	Stock standard	Ordering code R.H. clamp	Stock standard
2,0	20-22	8	16	308-155201-2022	■	408-155201-2022	■
	22-25	8		308-155201-2225	■	412-155201-2248	■
	25-29	10		310-155201-2529	■		
	29-34	10		310-155201-2934	■		
	34-40	12		312-155201-3440	■		
	40-48	12		312-155201-4048	■		
2,5	20-22	8	16	308-155251-2022	■	408-155251-2022	■
	22-25	8		308-155251-2225	■	412-155251-2248	■
	25-29	10		310-155251-2529	■		
	29-34	10		310-155251-2934	■		
	34-40	12		312-155251-3440	■		
	40-48	12		312-155251-4048	■		

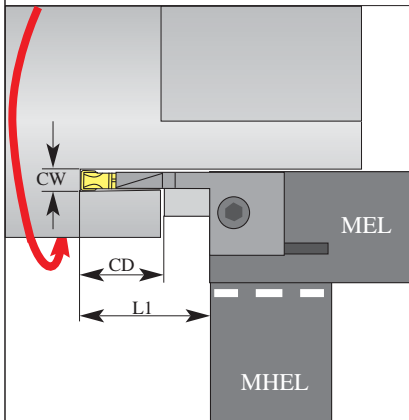

SUPPORT BLADES AND CLAMPS FOR
MINI FACE GROOVING:
L.H. TOOLHOLDERS / R.H. TURNING

SUPPORT BLADE

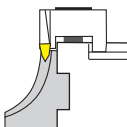

CLAMP

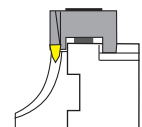

CW mm.	Outer-Ø* mm.	CD mm.	L1 mm.	Ordering code L.H. support blade	Stock standard	Ordering code L.H. clamp	Stock standard
2,0	20-22	8	16	308-155202-2022	■	408-155202-2022	■
	22-25	8		308-155202-2225	■	412-155202-2248	■
	25-29	10		310-155202-2529	■		
	29-34	10		310-155202-2934	■		
	34-40	12		312-155202-3440	■		
	40-48	12		312-155202-4048	■		
2,5	20-22	8	16	308-155252-2022	■	408-155252-2022	■
	22-25	8		308-155252-2225	■	412-155252-2248	■
	25-29	10		310-155252-2529	■		
	29-34	10		310-155252-2934	■		
	34-40	12		312-155252-3440	■		
	40-48	12		312-155252-4048	■		

*See page 23

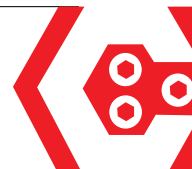

INTEGRAL SHANK TOOLHOLDER

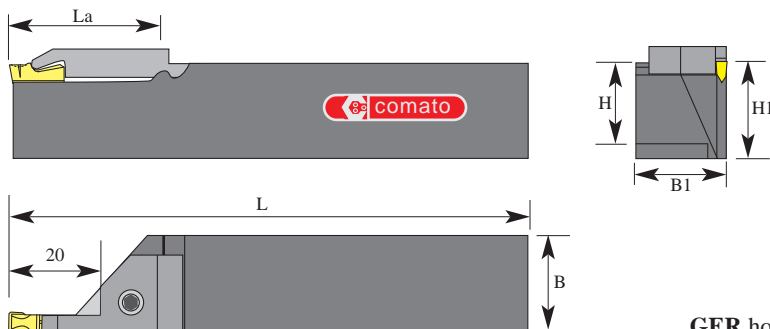

NOTE: Integral-shank toolholder are always supplied complete with clamp, screw and key.

GER holder shown

H/H1	Dimensions			clamp see page 19	Ordering code R.H. holder	Stock standard		Ordering code L.H. holder	Stock standard
	B/B1	L	La.						
12/16	12/16	150	36	CER/L 16-3	GER 1212M 3	■		GEL 1212M 3	■
16	16	150	36	CER/L 16-3	GER 1616M 3	■		GEL 1616M 3	■
16/20	16/20	150	36	CER/L 20-3	GER 1620M 3	■		GEL 1620M 3	■
20	20	150	36	CER/L 20-3	GER 2020M 3	■		GEL 2020M 3	■
20/25	20/25	125	36	CER/L 20-3	GER 2025K 3	■		GEL 2025K 3	■
25	25	150	36	CER/L 20-3	GER 2525M 3	■		GEL 2525M 3	■
25	25	150	43	CER/L 20-4	GER 2525M 4	■		GEL 2525M 4	■

See clamps for groove dimensions

TOOLHOLDER FOR DOUBLE SIDED SUPPORT BLADE

BEX20-.. is double sided

NOTE: Toolholders are supplied with screws for support blade and key onle. Clamps, support blades and screws for clamps must be ordered separately.

For inserts, see page 6 - 11.

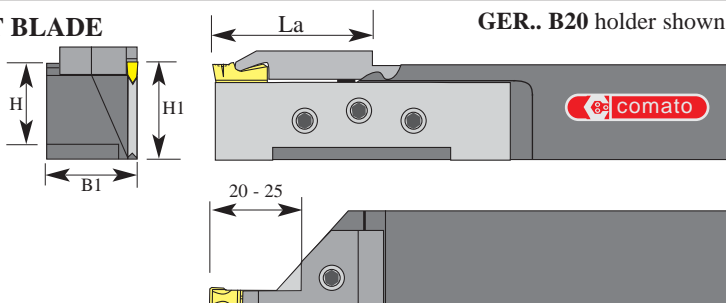

GER.. B20 holder shown

H/H1	Dimensions			supp. blade see page 19	Ordering code R.H. holder	Stock standard		Ordering code L.H. holder	Stock standard
	B/B1	L	La.						
20/25	25/20	120/125	36/41	BEX 20-..	GER 2025K B20	■		GEL 2025K B20	■
25	25	145/150	36/41	BEX 20-..	GER 2525M B20	■		GEL 2525M B20	■

See blades and clamps for groove dimensions

TOOLHOLDER FOR FOUR SIDED SUPPORT BLADE

BEX25-.. is four side

NOTE: Toolholders are supplied with screws for support blade and key onle. Clamps, support blades and screws for clamps must be ordered separately.

For inserts, see page 6 - 11.

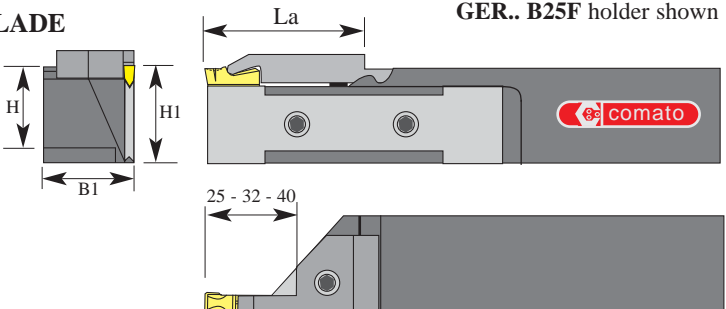

GER.. B25F holder shown

H/H1	Dimensions			supp. blade see page 19	Ordering code R.H. holder	Stock standard		Ordering code L.H. holder	Stock standard
	B/B1	L	La.						
25/32	32/25	202/210/219	43/50/59	BEX 25-..	GER 2532R B25F	■		GEL 2532R B25F	■
32	32	202/210/219	43/50/59	BEX 25-..	GER 3232R B25F	■		GEL 3232R B25F	■

See blades and clamps for groove dimensions

DOUBLE SIDED GROOVETURN SYSTEM

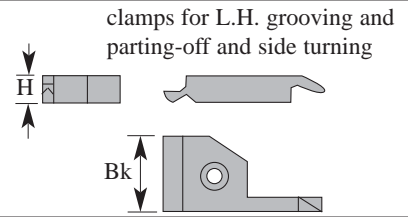
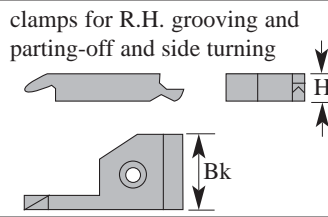
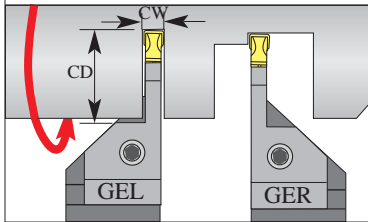

CW mm.	CD mm.	Dimensions			Ordering code R.H. clamp	Stock standard	Ordering code L.H. clamp	Stock standard
		H	BK	La*				
3	20	8	16	36	CER 16-3	■	CEL 16-3	■
3	20	8	20	36	CER 20-3	■	CEL 20-3	■
3	25	8	20	43	CER 25-3	■	CEL 25-3	■
4	20	8	20	43	CER 20-4	■	CEL 20-4	■

Double-sided support blades for R.H. / L.H. grooving and parting-off and side turning.

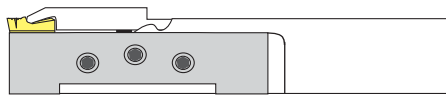

BEX20 shown in GER-B20 holder.

CW mm.	CD mm.	Dimensions			Ordering code support blade	Stock standard	Ordering code clamp	Stock standard
		L	H	La*				
3	20	145	20	36	BEX 20-3	■	CER/L 20-3	■
3	25	150	20	43	BEX 25-3	■	CER/L 25-3	■
4	20	150	20	43	BEX 20-4	■	CER/L 20-4	■

FOUR-DOUBLED SIDED GROOVETURN SYSTEM

CW mm.	CD mm.	Dimensions			Ordering code R.H. clamp	Stock standard	Ordering code L.H. clamp	Stock standard
		H	BK	La*				
3	25	8	24	43	CER 25-3-25	■	CEL 25-3-25	■
3	32	8	24	50	CER 25-3-32	■	CEL 25-3-32	■
4	32	8	24	50	CER 25-4-32	■	CEL 25-4-32	■
4	40	8	24	59	CER 25-4-40	■	CEL 25-4-40	■
5	40	8	24	59	CER 25-5-40	■	CEL 25-5-40	■

Four-sided support blades for R.H. / L.H. grooving and parting-off and side turning.

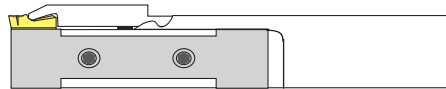

BEX25 shown in GER-B25F holder.

CW mm.	CD mm.	Dimensions			Ordering code support blade	Stock standard	Ordering code clamp	Stock standard
		L	H	La*				
3	25	205	27	43	BEX 25-3-25	■	CER/L 25-3-25	■
3	32	210	27	50	BEX 25-3-32	■	CER/L 25-3-32	■
4	32	210	27	50	BEX 25-4-32	■	CER/L 25-4-32	■
4	40	220	27	59	BEX 25-4-40	■	CER/L 25-4-40	■
5	40	220	27	59	BEX 25-5-40	■	CER/L 25-5-40	■

SPARE PARTS FOR THE GROOVETURN SYSTEM

Ordering code	Description	Number per holder
T15-M6-RL CQ-T15 K	Screw for	
T15-M5 CQ-T15	Screw for support blade BEX-20 Key for this clamp-screw	3
T25-M8-RL CQ-T25	Screw for clamp CER 25 Key for this clamp-screw	1
T25-M6 CQ-T25	Screw for support blade BEX-25 Key for this clamp-screw	2

NC-MODULAR SYSTEM

FOR EXTERNAL GROOVING, FACE GROOVING AND PARTING-OFF

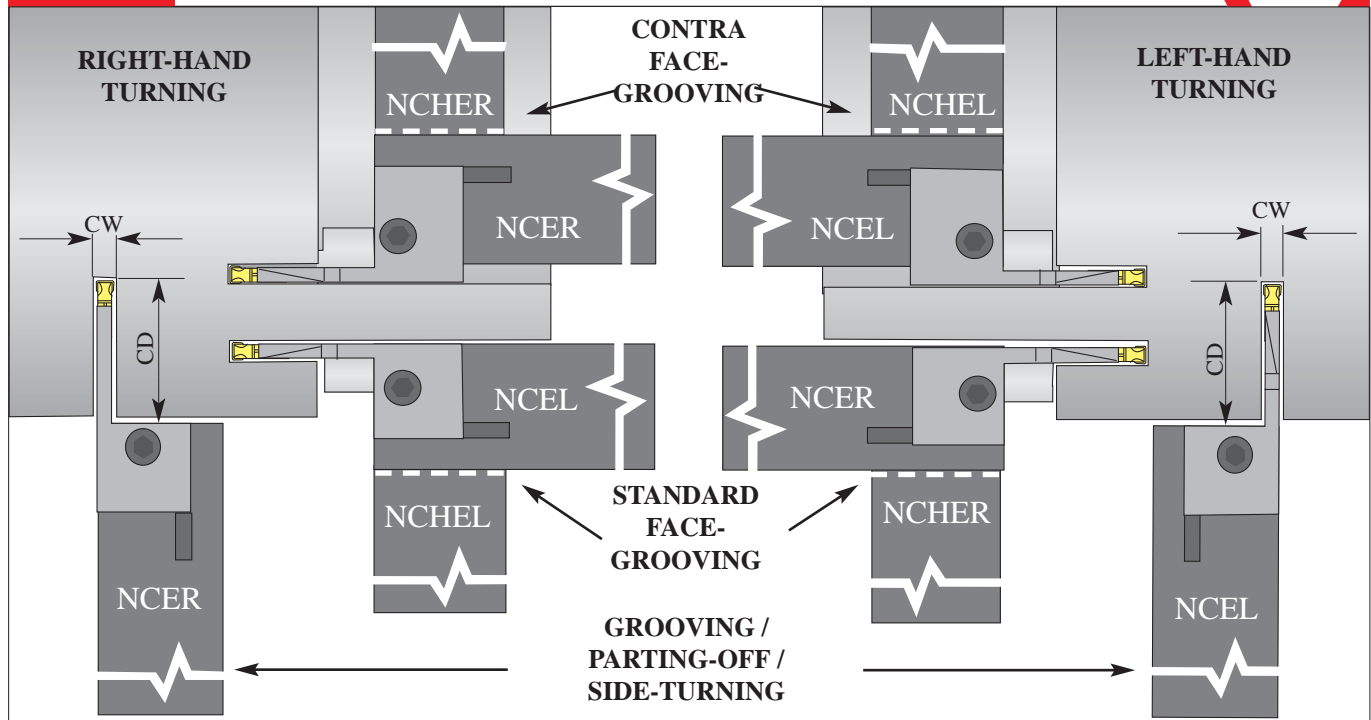
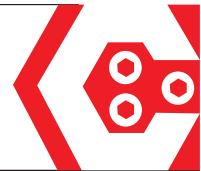

NC-BASIC TOOLHOLDER STRAIGHT

NOTE: Toolholders are supplied with screws for support blade and clamp only.
Clamps, support blades, keys and inserts must be ordered separately.
For clamps and support blades, see page 22, 24-29.
For inserts, see page 6 - 11.

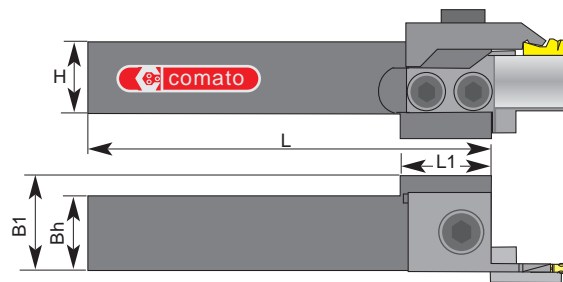
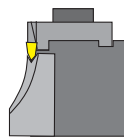

NCEL toolholder shown

Dimensions					CW max	CD max	Ordering code R.H. holder	Stock standard		Ordering code L.H. holder	Stock standard
H	Bh	L	L1	B1							
20	32	150	32	32	6	32	N CER 2032	■		N CEL 2032	■
25	25	150	32	32	6	32	N CER 2525	■		N CEL 2525	■
25	32	150	32	32	6	32	N CER 2532	■		N CEL 2532	■
32	32	150		32	10	40	N CER 3232	■		N CEL 3232	■
40	40	200		40	10	40	N CER 4040	■		N CEL 4040	■

NC-BASIC TOOLHOLDER 90° CRANKED

NOTE: Toolholders are supplied with screws for support blade and clamp only.
Clamps, support blades, keys and inserts must be ordered separately.
For clamps and support blades, see page 22, 24-29.
For inserts, see page 6 - 11.

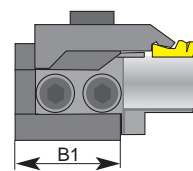
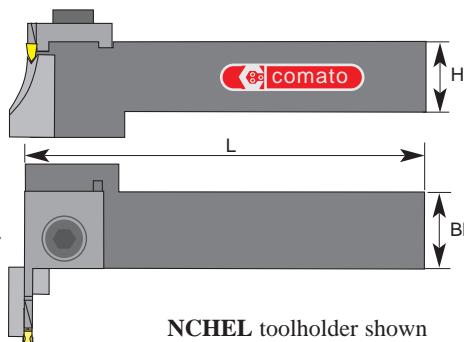

For 90° cranked toolholders, see also the Comato mini system, page 14-15.

NCHER toolholder shown

Dimensions					CW max	CD max	Ordering code R.H. holder	Stock standard		Ordering code L.H. holder	Stock standard
H	Bh	L	L1	B1							
20	35	150	30	35	4	25	N CER 2035	■		N CER 2035	■
25	25	150	30	35	6	40	N CER 2525	■		N CER 2525	■
32	35	150		35	10	40	N CER 3235	■		N CER 3235	■
40	40	200		40	10	40	N CER 4040	■		N CER 4040	■

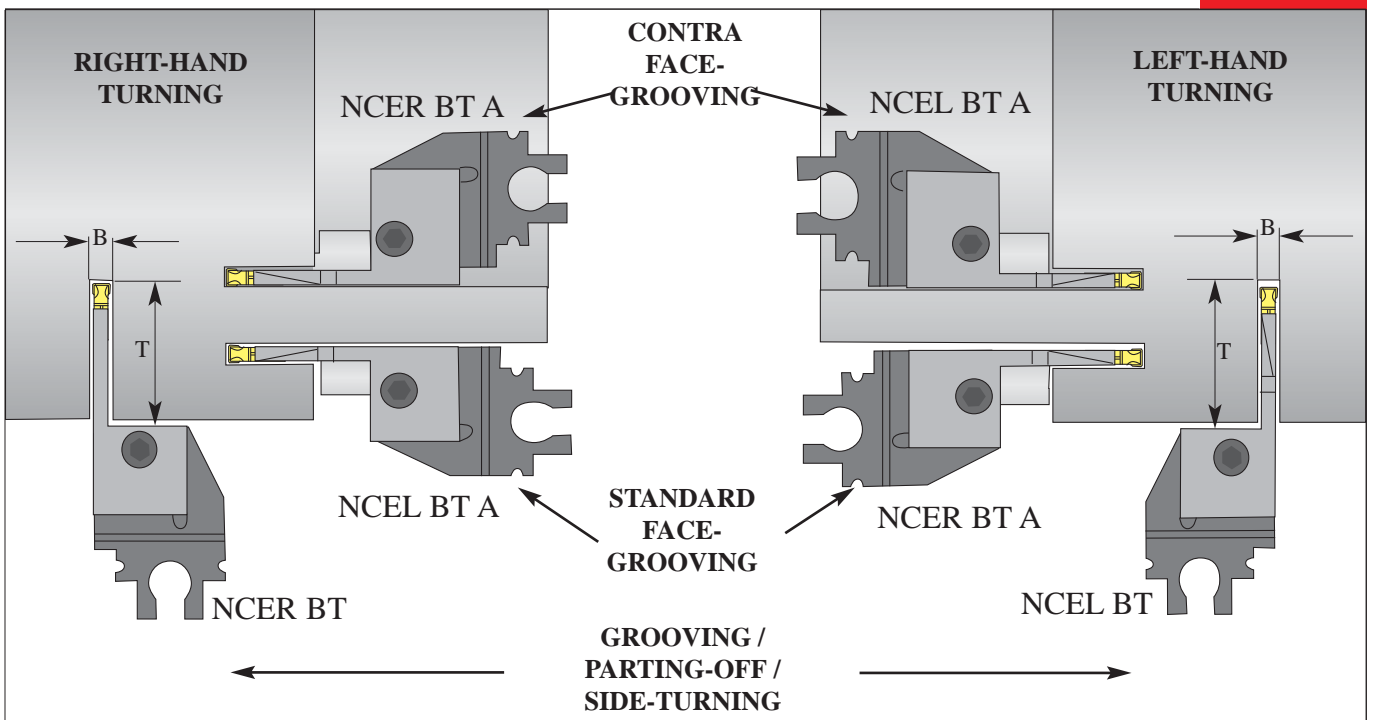

NC-BASIC BTS-TOOLHOLDER FOR GROOVING AND PARTING-OFF

NOTE: Toolholders are supplied with screws for support blade and clamp only. Clamps, support blades, keys and inserts must be ordered separately.

For clamps and support blades, see page 22.
For inserts, see page 6 - 11.

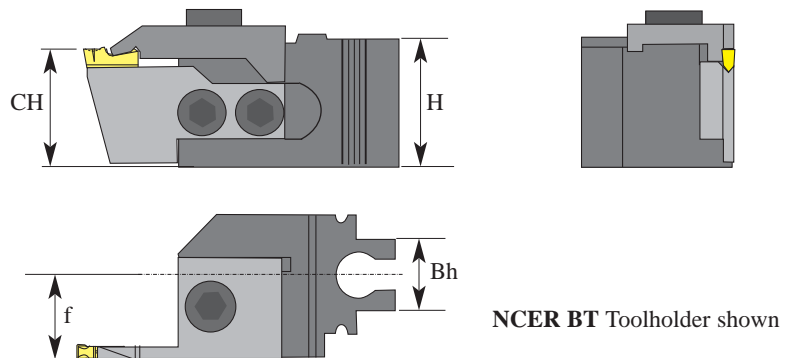

Dimension					CW max	CD max	Ordering code R.H. holder	Stock standard		Ordering code L.H. holder	Stock standard
H	Bh	CH	f	L							
29	25	25	19,5	50	4	25	NCER BT25	<input type="checkbox"/>		NCEL BT25	<input type="checkbox"/>
36	32	32	24	50	5	25	NCER BT32	<input type="checkbox"/>		NCEL BT32	<input type="checkbox"/>
45	40	40	30	50	8	40	NCER BT40	<input type="checkbox"/>		NCEL BT40	<input type="checkbox"/>

NC-BASIC BTS-TOOLHOLDER FOR TREPANNING

NOTE: Toolholders are supplied with screws for support blade and clamp only. Clamps, support blades, keys and inserts must be ordered separately.

For clamps and support blades, see page 24-29.
For inserts, see page 6 - 11.

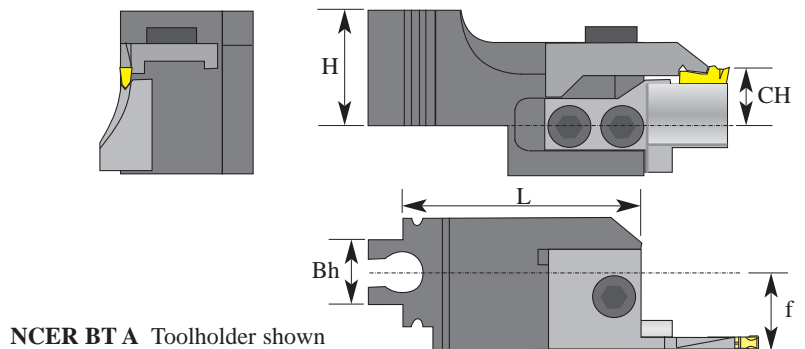

Dimension					CW max	CD max	Ordering code R.H. holder	Stock standard		Ordering code L.H. holder	Stock standard
H	Bh	CH	f	L							
29	25	14,5	19,5	60	4	25	NCER BT25 A	<input type="checkbox"/>		NCEL BT25 A	<input type="checkbox"/>
36	32	18	24	70	5	25	NCER BT32 A	<input type="checkbox"/>		NCEL BT32 A	<input type="checkbox"/>
45	40	22,5	30	75	8	35	NCER BT40 A	<input type="checkbox"/>		NCEL BT40 A	<input type="checkbox"/>

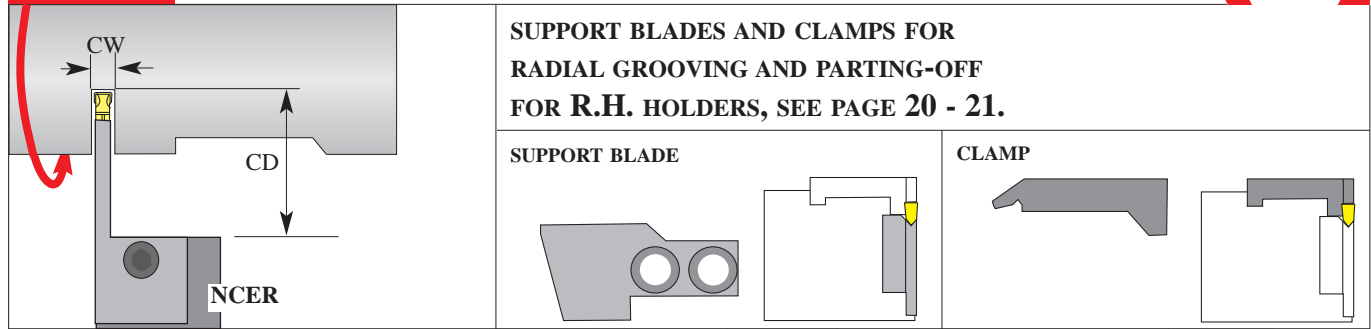
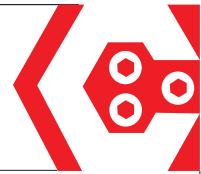

SUPPORT BLADES AND CLAMPS FOR RADIAL GROOVING AND PARTING-OFF FOR R.H. HOLDERS, SEE PAGE 20 - 21.

SUPPORT BLADE

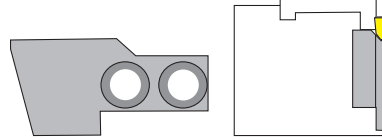

CLAMP

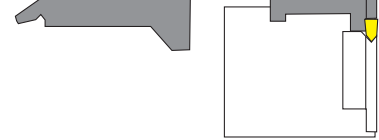

CW mm.	CD mm.	also suitable for NCER BT			Ordering code R.H. support blade	Stock standard		Ordering code R.H. clamp	Stock standard
		BT25	BT32	BT40					
2	20	*	*	*	320 15021	■		420 15021	■
2,5	20	*	*	*	320 150251	■		420 150251	■
3	20	*	*	*	320 15031	■		420 15031	■
4	25	*	*	*	325 15041	■		425 15041	■
5	25		*	*	325 15051	■		425 15051	■
6	32			*	332 15061	■		432 15061	■
8	40			*	340 15081	■		440 15081	■
10	20				320 15101	□		420 15101	□
10	40				340 15101	□		440 15101	□

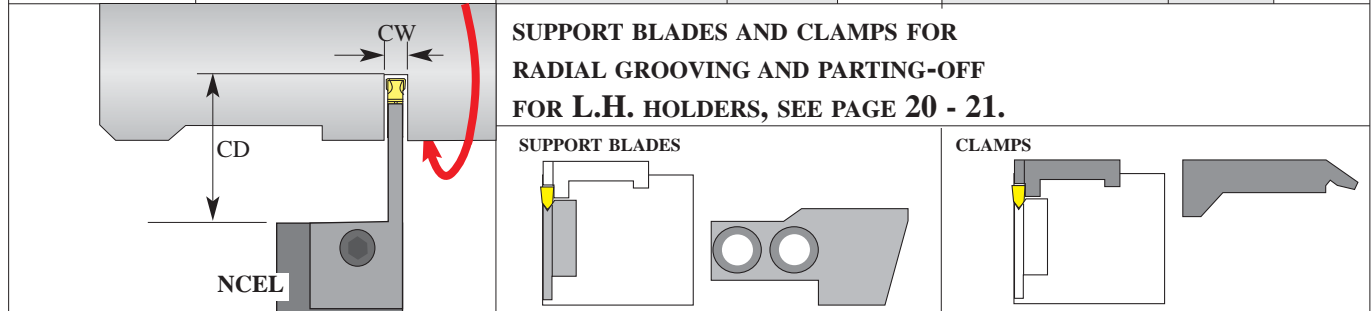

SUPPORT BLADES AND CLAMPS FOR RADIAL GROOVING AND PARTING-OFF FOR L.H. HOLDERS, SEE PAGE 20 - 21.

SUPPORT BLADES

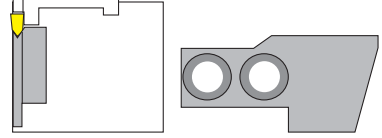

CLAMPS



CW mm.	CD mm.	also suitable for NCER BT			Ordering code L.H. support blade	Stock standard		Ordering code L.H. clamp	Stock standard
		BT25	BT32	BT40					
2	20	*	*	*	320 15022	■		420 15022	■
2,5	20	*	*	*	320 150252	■		420 150252	■
3	20	*	*	*	320 15032	■		420 15032	■
4	25	*	*	*	325 15042	■		425 15042	■
5	25		*	*	325 15052	■		425 15052	■
6	32			*	332 15062	■		432 15062	■
8	40			*	340 15082	■		440 15082	■
10	20				320 15102	□		420 15102	□
10	40				340 15102	□		440 15102	□

SPARE PARTS FOR THE ENTIRE NC-MODULAR SYSTEM

Ordering code	Description	Number per holder
M8 X 16MC HEX M6	Screw for clamp Key for clamp-screw	1
M6 X 25MK HEX M4	Screw for support blade Key for support blade-screw	2

Recommendations for Comato face grooving and trepanning operations:

- Cutting speed 80% of cutting speed for parting-off
- Feed 50% of feed for parting-off
- Apply sufficient cooling directly on cutting edge

Profile and contour turning:

The initial face groove must be made within the diameter range of assembly. From this first groove it is possible to turn toward larger or smaller diameters.

Trepanning:

When trepanning it is recommendable to stop cutting just before the tool penetrates through, then the slug can be knocked out with a hammer.

Special face grooving circumstances:

A: Close to a boss:

-Turning R.H. / Holder L.H.

or

-Turning L.H. / Holder R.H.

(STANDARD support blade & clamp).

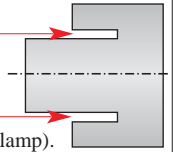

B: In a blind hole:

-Turning R.H. / Holder L.H.

or

-Turning L.H. / Holder R.H.

(CONTRA support blade & clamp)

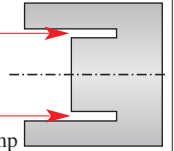

NOTE:

When ordering support blades and clamps for face grooving, always consider:

- * Turning direction (R.H. or L.H.)
- * Toolholder execution (R.H. or L.H.)
- * With of groove (CW)
- * Outer diameter of groove.

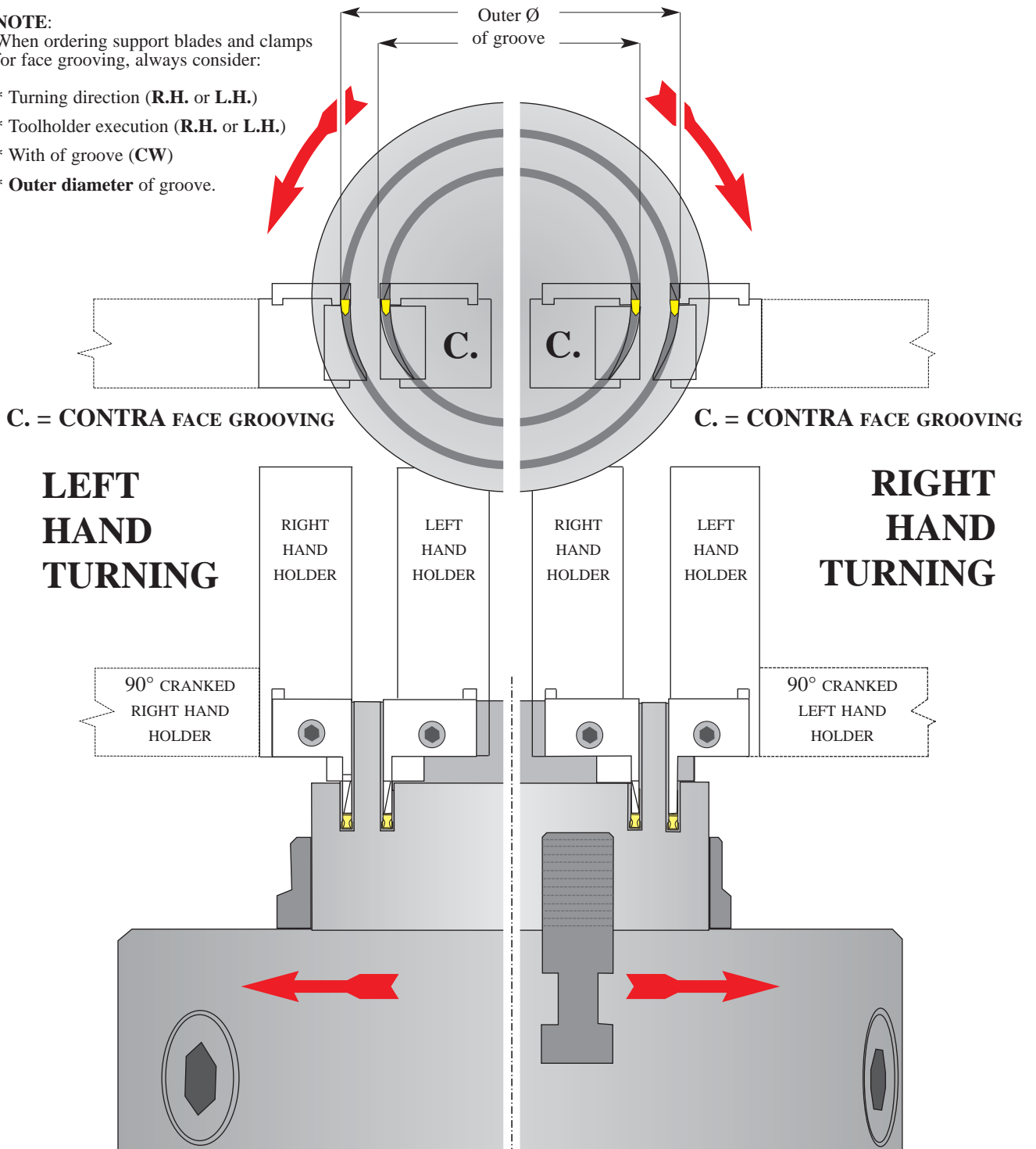

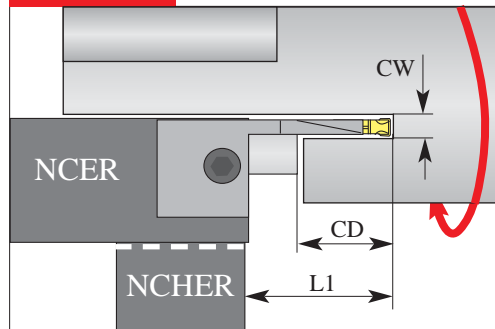
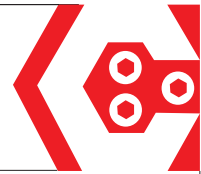

**SUPPORT BLADES AND CLAMPS FOR
STANDARD FACE GROOVING:
R.H. HOLDERS / L.H. TURNING
FOR HOLDERS, SEE PAGE 20 AND 21.**

SUPPORT BLADE

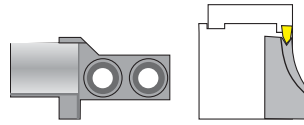

CLAMP

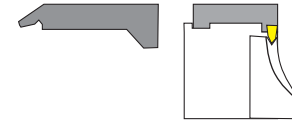

CW mm.	Outer Ø mm.	CD mm.	L1 mm.	Ordering code	Stock standard	Ordering code	Stock standard		
3	40 - 45	10	25	310 15031 040	<input type="checkbox"/>	412 15031 040	<input type="checkbox"/>		
	45 - 50	10		310 15031 045	<input type="checkbox"/>				
	50 - 60	12		312 15031 050	<input type="checkbox"/>				
	60 - 75	12		312 15031 060	<input type="checkbox"/>				
	75 - 100	16		316 15031 075	<input type="checkbox"/>			416 15031 075	<input type="checkbox"/>
	100 - 150	16		316 15031 100	<input type="checkbox"/>				
	150 - 250	20		320 15031 150	<input type="checkbox"/>			420 15031 150	<input type="checkbox"/>
	250 - 450	20		320 15031 250	<input type="checkbox"/>				
450 - ~	20	320 15031 450	<input type="checkbox"/>						
4	40 - 45	10	25	310 15041 040	<input type="checkbox"/>	412 15041 040	<input type="checkbox"/>		
	45 - 50	10		310 15041 045	<input type="checkbox"/>				
	50 - 60	12		312 15041 050	<input type="checkbox"/>				
	60 - 75	12		312 15041 060	<input type="checkbox"/>				
	75 - 100	16		316 15041 075	<input type="checkbox"/>			416 15041 075	<input type="checkbox"/>
	100 - 150	16		316 15041 100	<input type="checkbox"/>				
	150 - 250	20		320 15041 150	<input type="checkbox"/>			420 15041 150	<input type="checkbox"/>
	250 - 450	20		320 15041 250	<input type="checkbox"/>				
450 - ~	20	320 15041 450	<input type="checkbox"/>						
5	40 - 45	10	25	310 15051 040	<input type="checkbox"/>	412 15051 040	<input type="checkbox"/>		
	45 - 50	10		310 15051 045	<input type="checkbox"/>				
	50 - 60	12		312 15051 050	<input type="checkbox"/>				
	60 - 75	12		312 15051 060	<input type="checkbox"/>				
	75 - 100	16		316 15051 075	<input type="checkbox"/>			416 15051 075	<input type="checkbox"/>
	100 - 150	16		316 15051 100	<input type="checkbox"/>				
	150 - 250	20		320 15051 150	<input type="checkbox"/>			420 15051 150	<input type="checkbox"/>
	250 - 450	20		320 15051 250	<input type="checkbox"/>				
450 - ~	20	320 15051 450	<input type="checkbox"/>						
6	40 - 50	10	25	310 15061 040	<input type="checkbox"/>	412 15061 040	<input type="checkbox"/>		
	50 - 75	12		312 15061 050	<input type="checkbox"/>				
	75 - 150	16		316 15061 075	<input type="checkbox"/>				
	150 - 300	20		320 15061 150	<input type="checkbox"/>			420 15061 075	<input type="checkbox"/>
300 - ~	20	320 15061 300	<input type="checkbox"/>						
8	40 - 50	10	25	310 15081 040	<input type="checkbox"/>	412 15081 040	<input type="checkbox"/>		
	50 - 75	12		312 15081 050	<input type="checkbox"/>				
	75 - 150	16		316 15081 075	<input type="checkbox"/>				
	150 - 300	20		320 15081 150	<input type="checkbox"/>			420 15081 075	<input type="checkbox"/>
300 - ~	20	320 15081 300	<input type="checkbox"/>						
10	70 - 150	40	45	340 15101 070		440 15101 070			
	150 - 300	40		340 15101 150					
	300 - ~	40		340 15101 300					

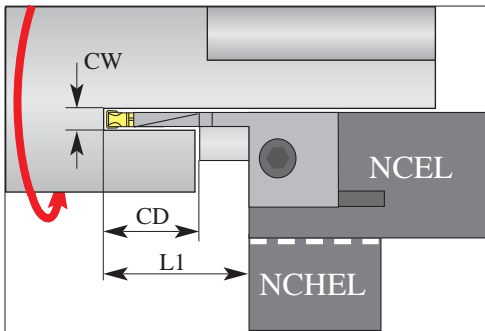

**SUPPORT BLADES AND CLAMPS FOR
STANDARD FACE GROOVING:
L.H. HOLDERS / R.H. TURNING
FOR HOLDERS, SEE PAGE 20 AND 21.**

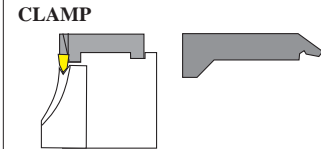
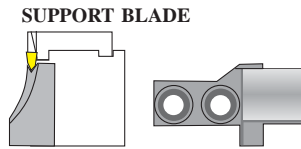

CW mm.	Outer Ø mm.	CD mm.	L1 mm.	Ordering code	Stock standard	Ordering code	Stock standard
3	40 - 45	10	25	310 15032 040	<input type="checkbox"/>	412 15032 040	<input type="checkbox"/>
	45 - 50	10		310 15032 045	<input type="checkbox"/>		
	50 - 60	12		312 15032 050	<input type="checkbox"/>		
	60 - 75	12		312 15032 060	<input type="checkbox"/>		
	75 - 100	16		316 15032 075	<input type="checkbox"/>	416 15032 075	<input type="checkbox"/>
	100 - 150	16		316 15032 100	<input type="checkbox"/>		
	150 - 250	20		320 15032 150	<input type="checkbox"/>	420 15032 150	<input type="checkbox"/>
	250 - 450	20		320 15032 250	<input type="checkbox"/>		
450 - ~	20	320 15032 450	<input type="checkbox"/>				
4	40 - 45	10	25	310 15042 040	<input type="checkbox"/>	412 15042 040	<input type="checkbox"/>
	45 - 50	10		310 15042 045	<input type="checkbox"/>		
	50 - 60	12		312 15042 050	<input type="checkbox"/>		
	60 - 75	12		312 15042 060	<input type="checkbox"/>		
	75 - 100	16		316 15042 075	<input type="checkbox"/>	416 15042 075	<input type="checkbox"/>
	100 - 150	16		316 15042 100	<input type="checkbox"/>		
	150 - 250	20		320 15042 150	<input type="checkbox"/>	420 15042 150	<input type="checkbox"/>
	250 - 450	20		320 15042 250	<input type="checkbox"/>		
450 - ~	20	320 15042 450	<input type="checkbox"/>				
5	40 - 45	10	25	310 15052 040	<input type="checkbox"/>	412 15052 040	<input type="checkbox"/>
	45 - 50	10		310 15052 045	<input type="checkbox"/>		
	50 - 60	12		312 15052 050	<input type="checkbox"/>		
	60 - 75	12		312 15052 060	<input type="checkbox"/>		
	75 - 100	16		316 15052 075	<input type="checkbox"/>	416 15052 075	<input type="checkbox"/>
	100 - 150	16		316 15052 100	<input type="checkbox"/>		
	150 - 250	20		320 15052 150	<input type="checkbox"/>	420 15052 150	<input type="checkbox"/>
	250 - 450	20		320 15052 250	<input type="checkbox"/>		
450 - ~	20	320 15052 450	<input type="checkbox"/>				
6	40 - 50	10	25	310 15062 040	<input type="checkbox"/>	412 15062 040	<input type="checkbox"/>
	50 - 75	12		312 15062 050	<input type="checkbox"/>		
	75 - 150	16		316 15062 075	<input type="checkbox"/>	420 15062 075	<input type="checkbox"/>
	150 - 300	20		320 15062 150	<input type="checkbox"/>		
300 - ~	20	320 15062 300	<input type="checkbox"/>				
8	40 - 50	10	25	310 15082 040	<input type="checkbox"/>	412 15082 040	<input type="checkbox"/>
	50 - 75	12		312 15082 050	<input type="checkbox"/>		
	75 - 150	16		316 15082 075	<input type="checkbox"/>	420 15082 075	<input type="checkbox"/>
	150 - 300	20		320 15082 150	<input type="checkbox"/>		
300 - ~	20	320 15082 300	<input type="checkbox"/>				
10	70 - 150	40	45	340 15102 070		440 15102 070	
	150 - 300	40		340 15102 150			
	300 - ~	40		340 15102 300			

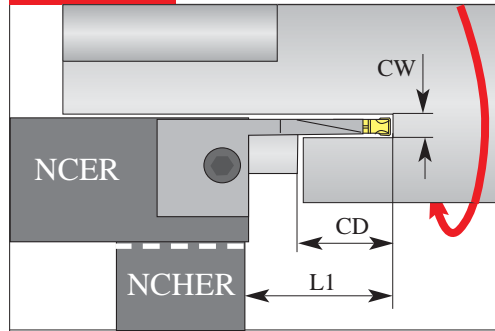
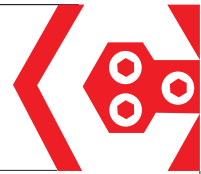

**SUPPORT BLADES AND CLAMPS FOR
STANDARD FACE GROOVING:
R.H. HOLDERS / L.H. TURNING
FOR HOLDERS, SEE PAGE 20 AND 21.**

SUPPORT BLADE

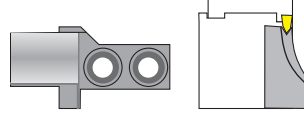

CLAMP

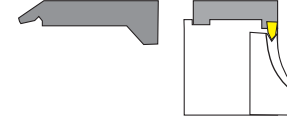

CW mm.	Outer Ø mm.	CD mm.	L1 mm.	Ordering code	Stock standard	Ordering code	Stock standard		
3	40 - 45	12	32	312 15031 040	■	416 15031 040	■		
	45 - 50	12		312 15031 045	■				
	50 - 60	16		316 15031 050	■				
	60 - 75	16		316 15031 060	■				
	75 - 100	20		320 15031 075	■		420 15031 075	■	
	100 - 150	20		320 15031 100	■				
	150 - 250	25		325 15031 150	■		425 15031 150	■	
	250 - 450	25		325 15031 250	■				
450 - ~	25	325 15031 450	■						
4	40 - 45	12	32	312 15041 040	■	416 15041 040	■		
	50 - 60	16		316 15041 050	■				
	60 - 75	16		316 15041 060	■				
	75 - 100	20		320 15041 075	■		420 15041 075	■	
	100 - 150	20		320 15041 100	■				
	150 - 250	25		325 15041 150	■		425 15041 150	■	
	250 - 450	25		325 15041 250	■				
	450 - ~	25		325 15041 450	■				
5	40 - 45	12	32	312 15051 040	■	416 15051 040	■		
	50 - 60	16		316 15051 050	■				
	60 - 75	16		316 15051 060	■				
	75 - 100	20		320 15051 075	■		420 15051 075	■	
	100 - 150	20		320 15051 100	■				
	150 - 250	25		325 15051 150	■		425 15051 150	■	
	250 - 450	25		325 15051 250	■				
	450 - ~	25		325 15051 450	■				
	70 - 100	30		40	330 15051 070		■	430 15051 070	■
	100 - 150	30			330 15051 100		■		
	150 - 250	30			330 15051 150		■		
	250 - 450	30			330 15051 250		■		
450 - ~	30	330 15051 450	■						
6	40 - 50	12	25	312 15061 040	■	416 15061 040	■		
	50 - 75	16		316 15061 050	■				
	75 - 150	20		320 15061 075	■		425 15061 075	■	
	150 - 300	25		325 15061 150	■				
	300 - ~	25		325 15061 300	■				
	70 - 150	35		40	335 15061 070		■	435 15061 070	■
	150 - 300	35			335 15061 150		■		
	300 - ~	35			335 15061 300		■		
8	40 - 50	12	32	312 15081 040	□	416 15081 040	□		
	50 - 75	16		316 15081 050	□				
	75 - 150	20		320 15081 075	□		425 15081 075	□	
	150 - 300	25		325 15081 150	□				
	300 - ~	25		325 15081 300	□				
	70 - 150	35		40	335 15081 070		□	435 15081 070	□
	150 - 300	35			335 15081 150		□		
	300 - ~	35			335 15081 300		□		

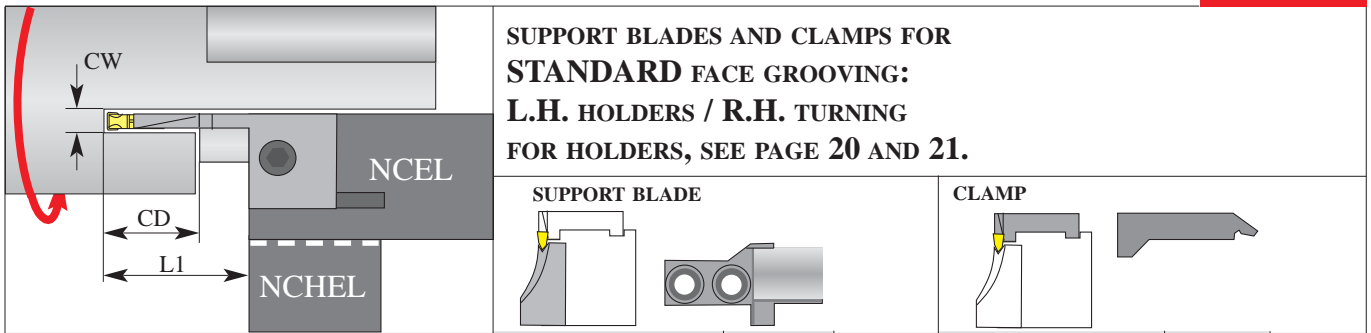

**SUPPORT BLADES AND CLAMPS FOR
STANDARD FACE GROOVING:
L.H. HOLDERS / R.H. TURNING
FOR HOLDERS, SEE PAGE 20 AND 21.**

CW mm.	Outer Ø mm.	CD mm.	L1 mm.	Ordering code	Stock standard	Ordering code	Stock standard		
3	40 - 45	12	32	312 15032 040	■	416 15032 040	■		
	45 - 50	12		312 15032 045	■				
	50 - 60	16		316 15032 050	■				
	60 - 75	16		316 15032 060	■				
	75 - 100	20		320 15032 075	■	420 15032 075	■		
	100 - 150	20		320 15032 100	■				
	150 - 250	25		325 15032 150	■				
	250 - 450	25		325 15032 250	■				
450 - ~	25	325 15032 450	■	425 15032 150	■				
4	40 - 45	12	32	312 15042 040	■	416 15042 040	■		
	50 - 60	16		316 15042 050	■				
	60 - 75	16		316 15042 060	■				
	75 - 100	20		320 15042 075	■				
	100 - 150	20		320 15042 100	■	420 15042 075	■		
	150 - 250	25		325 15042 150	■				
	250 - 450	25		325 15042 250	■				
	450 - ~	25		325 15042 450	■			425 15042 150	■
5	40 - 45	12	32	312 15052 040	■	416 15052 040	■		
	50 - 60	16		316 15052 050	■				
	60 - 75	16		316 15052 060	■				
	75 - 100	20		320 15052 075	■				
	100 - 150	20		320 15052 100	■	420 15052 075	■		
	150 - 250	25		325 15052 150	■				
	250 - 450	25	325 15052 250	■	425 15052 150	■			
	450 - ~	25	325 15052 450	■					
	70 - 100	30	40	330 15052 070			■	430 15052 070	■
	100 - 150	30		330 15052 100			■		
150 - 250	30	330 15052 150		■					
250 - 450	30	330 15052 250		■					
450 - ~	30	330 15052 450	■						
6	40 - 50	12	25	312 15062 040	■	416 15062 040	■		
	50 - 75	16		316 15062 050	■				
	75 - 150	20		320 15062 075	■	425 15062 075	■		
	150 - 300	25	325 15062 150	■					
	300 - ~	25	325 15062 300	■					
	70 - 150	35	40	335 15062 070	■			435 15062 070	■
	150 - 300	35		335 15062 150	■				
300 - ~	35	335 15062 300		■					
8	40 - 50	12	32	312 15082 040	□	416 15082 040	□		
	50 - 75	16		316 15082 050	□				
	75 - 150	20		320 15082 075	□	425 15082 075	□		
	150 - 300	25	325 15082 150	□					
	300 - ~	25	325 15082 300	□					
	70 - 150	35	40	335 15082 070	□			435 15082 070	□
	150 - 300	35		335 15082 150	□				
300 - ~	35	335 15082 300		□					

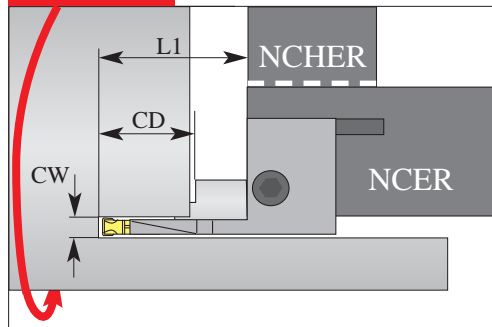
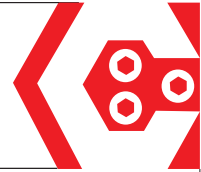

SUPPORT BLADES AND CLAMPS FOR
CONTRA FACE GROOVING:
R.H. HOLDERS / R.H. TURNING
FOR HOLDERS, SEE PAGE 20 AND 21.

SUPPORT BLADE

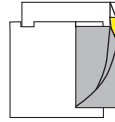
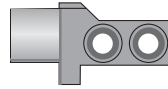

CLAMP

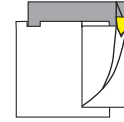

CW mm.	Outer Ø mm.	CD mm.	L1 mm.	Ordering code	Stock standard	ordering code	Stock standard
3	40 - 45	12	32	312 15031 040C	■	416 15031 040C	■
	45 - 50	12		312 15031 045C	■		
	50 - 60	16		316 15031 050C	■		
	60 - 75	16		316 15031 060C	■		
	75 - 100	20		320 15031 075C	■	420 15031 075C	■
	100 - 150	20		320 15031 100C	■	425 15031 150C	■
	150 - 250	25		325 15031 150C	■		
	250 - 450	25		325 15031 250C	■		
450 - ~	25	325 15031 450C	■				
4	40 - 45	12	32	312 15041 040C	■	416 15041 040C	■
	50 - 60	16		316 15041 050C	■		
	60 - 75	16		316 15041 060C	■		
	75 - 100	20		320 15041 075C	■		
	100 - 150	20		320 15041 100C	■	420 15041 075C	■
	150 - 250	25		325 15041 150C	■	425 15041 150C	■
	250 - 450	25		325 15041 250C	■		
	450 - ~	25		325 15041 450C	■		
5	40 - 45	12	32	312 15051 040C	■		
	50 - 60	16		316 15051 050C	■		
	60 - 75	16		316 15051 060C	■		
	75 - 100	20		320 15051 075C	■		
	100 - 150	20		320 15051 100C	■	420 15051 075C	■
	150 - 250	25		325 15051 150C	■	425 15051 150C	■
	250 - 450	25		325 15051 250C	■		
	450 - ~	25		325 15051 450C	■		
	70 - 100	30		330 15051 070C	■		
	100 - 150	30		330 15051 100C	■		
150 - 250	30	330 15051 150C	■				
250 - 450	30	330 15051 250C	■				
450 - ~	30	330 15051 450C	■				
6	40 - 50	12	32	312 15061 040C	■	416 15061 040C	■
	50 - 75	16		316 15061 050C	■		
	75 - 150	20		320 15061 075C	■		
	150 - 300	25		325 15061 150C	■		
	300 - ~	25		325 15061 300C	■	425 15061 075C	■
	70 - 150	35		335 15061 070C	■	435 15061 070C	■
	150 - 300	35		335 15061 150C	■		
300 - ~	35	335 15061 300C	■				
8	40 - 50	12	32	312 15081 040C	■	416 15081 040C	■
	50 - 75	16		316 15081 050C	■		
	75 - 150	20		320 15081 075C	■		
	150 - 300	25		325 15081 150C	■		
	300 - ~	25		325 15081 300C	■	425 15081 075C	■
	70 - 150	35		335 15081 070C	■	435 15081 070C	■
150 - 300	35	335 15081 150C	■				
300 - ~	35	335 15081 300C	■				
10	70 - 150	40	45	340 15101 070C	■	440 15101 070C	■
	150 - 300	40		340 15101 150C	■		
	300 - ~	40		340 15101 300C	■		

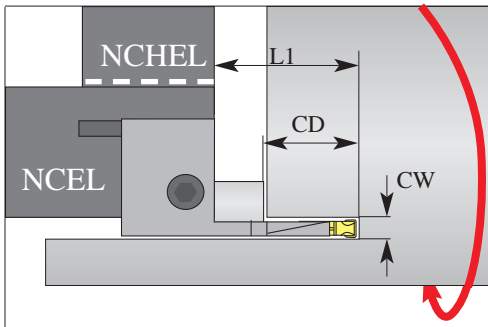

**SUPPORT BLADES AND CLAMPS FOR
CONTRA FACE GROOVING:
L.H. HOLDERS / L.H. TURNING
FOR HOLDERS, SEE PAGE 20 AND 21.**

SUPPORT BLADE

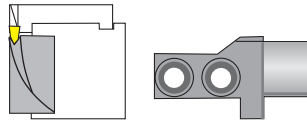

CLAMP

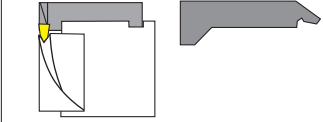

CW mm.	Outer Ø mm.	CD mm.	L1 mm.	Ordering code	Stock standard	Ordering code	Stock standard			
3	40 - 45	12	32	312 15032 040C	■	416 15032 040C	■			
	45 - 50	12		312 15032 045C	■					
	50 - 60	16		316 15032 050C	■					
	60 - 75	16		316 15032 060C	■					
	75 - 100	20		320 15032 075C	■					
	100 - 150	20		320 15032 100C	■					
	150 - 250	25		325 15032 150C	■					
	250 - 450	25		325 15032 250C	■					
450 - ~	25	325 15032 450C	■							
4	40 - 45	12	32	312 15042 040C	■	416 15042 040C	■			
	50 - 60	16		316 15042 050C	■					
	60 - 75	16		316 15042 060C	■					
	75 - 100	20		320 15042 075C	■					
	100 - 150	20		320 15042 100C	■					
	150 - 250	25		325 15042 150C	■					
	250 - 450	25		325 15042 250C	■					
	450 - ~	25		325 15042 450C	■					
5	40 - 45	12	32	312 15052 040C	■	416 15052 040C	■			
	50 - 60	16		316 15052 050C	■					
	60 - 75	16		316 15052 060C	■					
	75 - 100	20		320 15052 075C	■					
	100 - 150	20		320 15052 100C	■					
	150 - 250	25		325 15052 150C	■					
	250 - 450	25		325 15052 250C	■					
	450 - ~	25		325 15052 450C	■					
	70 - 100	30		40	330 15052 070C			■	430 15052 070C	■
	100 - 150	30			330 15052 100C			■		
150 - 250	30	330 15052 150C	■							
6	40 - 50	12	32	312 15062 040C	■	416 15062 040C	■			
	50 - 75	16		316 15062 050C	■					
	75 - 150	20		320 15062 075C	■					
	150 - 300	25		325 15062 150C	■					
	300 - ~	25		325 15062 300C	■					
	70 - 150	35		40	335 15062 070C			■	435 15062 070C	■
	150 - 300	35			335 15062 150C			■		
	300 - ~	35			335 15062 300C			■		
8	40 - 50	12	32	312 15082 040C	■	416 15082 040C	■			
	50 - 75	16		316 15082 050C	■					
	75 - 150	20		320 15082 075C	■					
	150 - 300	25		325 15082 150C	■					
	300 - ~	25		325 15082 300C	■					
	70 - 150	35		40	335 15082 070C			■	435 15082 070C	■
	150 - 300	35			335 15082 150C			■		
	300 - ~	35			335 15082 300C			■		
10	70 - 150	40	45	340 15102 070C	■	440 15102 070C	■			
	150 - 300	40		340 15102 150C	■					
	300 - ~	40		340 15102 300C	■					

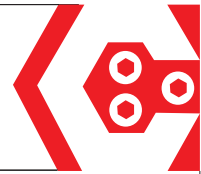

DOUBLE-ENDED MULTI-BLADE

Fits in most blade holders available on the market

For holders, see page 42

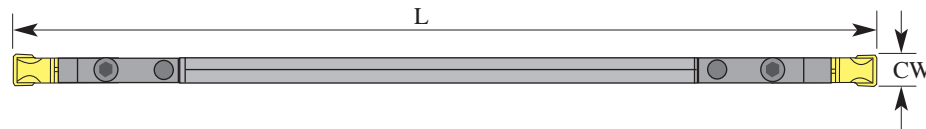

NOTE: Multi-blades are supplied with screws for clamp only.
Clamps, keys and inserts can be ordered separately.

For inserts, see page 6 - 10.

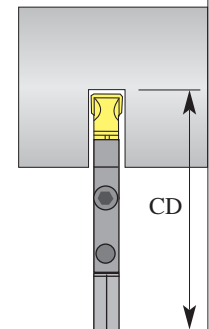

CW mm.	CD mm.	Dimensions			Ordering code Multi-blade	Stock standard		Ordering code Clamp	Stock standard
		H	H1	L					
4	32	26	20	120	MBEX 4	■			
4	100	32	25	250	MBEX 4 L	■	154 2621 40	■	
5	40	32	25	150	MBEX 5	■			
5	100	32	25	250	MBEX 5 L	■	154 3225 50	■	
6	40	32	25	150	MBEX 6	■			
6	100	32	25	250	MBEX 6 L	■	154 3225 60	■	
8	40	32	25	150	MBEX 8	■			
8	100	32	25	250	MBEX 8 L	■	154 3225 80	■	
6	100	52	45	260	SMBEX 6-52	□	154 3225 60	■	
8	100	52	45	260	SMBEX 8-52	□	154 3225 80	■	
10	100	52	45	260	SMBEX 10-52	□	154 3225 100	□	

SPARE PARTS FOR MULTI-BLADE

Ordering code	Description	Number per clamp
M2 X 12MC HEX M1,5	Screw for MBEX 4 / 154-2621-40 Key for this screw	1
M3 X 12 T10	Screw for MBEX 5 / 154-3225-50	1
M3 X 12MC	Screw for MBEX 6 / 154-3225-60 MBEX 8 / 154-3225-80 MBEX 10 / 154-3225-100	1 1 1
HEX M2,5	Key for this screw	1

T300 BASIC TOOLHOLDER

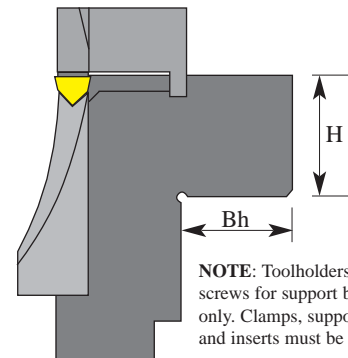
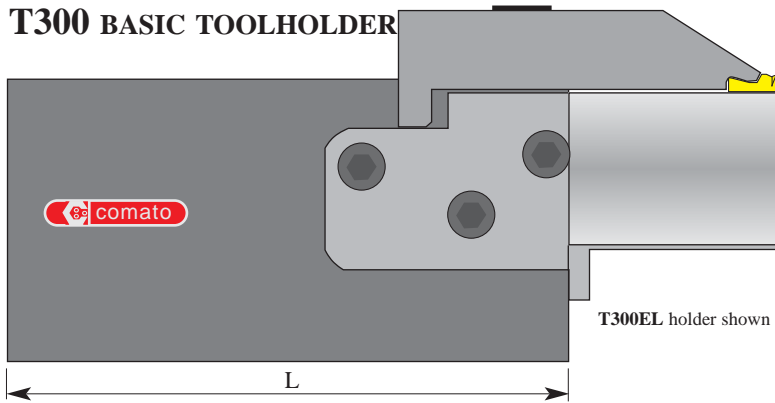

NOTE: Toolholders are supplied with screws for support blade and clamp only. Clamps, support blades, keys and inserts must be ordered separately.

For T300 support blades and clamps see page 31 - 33.

H	Dimensions		CW max.	CD max.	Ordering code R.H. Toolholder	Stock standard	Ordering code L.H. Toolholder	Stock standard
	Bh	L						
25	25	150	10	75	T300ER 2525	■	T300EL 2525	■
32	32	150	10	100	T300ER 3232	■	T300EL 3232	■
40	40	150	10	100	T300ER 4040	■	T300EL 4040	■

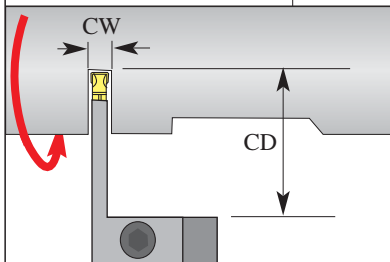

SUPPORT BLADES AND CLAMPS FOR RADIAL GROOVING AND PARTING-OFF FOR R.H. HOLDERS

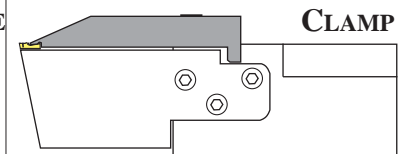
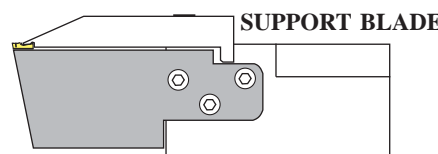

CW mm.	CD mm.	Ordering code support blade	stock standard	Ordering code R.H. clamp	stock standard
6	75	1502 7506	■	1503 75061	■
6	100	1502 10006	■	1503 100061	■
10	50	1502 5010	■	1503 50101	■
10	75	1502 7510	■	1503 75101	■
10	100	1502 10010	■	1503 100101	■

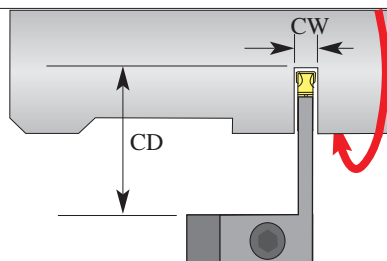

SUPPORT BLADES AND CLAMPS FOR RADIAL GROOVING AND PARTING-OFF FOR L.H. HOLDERS

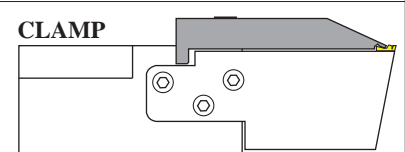
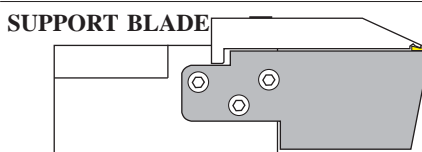

CW mm.	CD mm.	Ordering code support blade	stock standard	Ordering code L.H. clamp	stock standard
6	75	1502 7506	■	1503 75062	■
6	100	1502 10006	■	1503 100062	■
10	50	1502 5010	■	1503 50102	■
10	75	1502 7510	■	1503 75102	■
10	100	1502 10010	■	1503 100102	■

Ordering code	Description	Number per holder
M10 X 30MC HEX M8	Screw for clamp	1
M8 X 20MK HEX M5	Key for clamp-screw	
	Screw for clamp	3
	Key for clamp-screw	

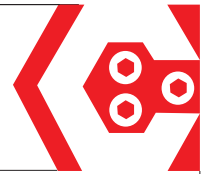

SPARE PARTS FOR FACE GROOVING

(SUPPORT BLADES ARE SUITABLE FOR BOTH R.H. AND L.H. HOLDERS)

FOR HOLDERS, SEE PAGE 31.

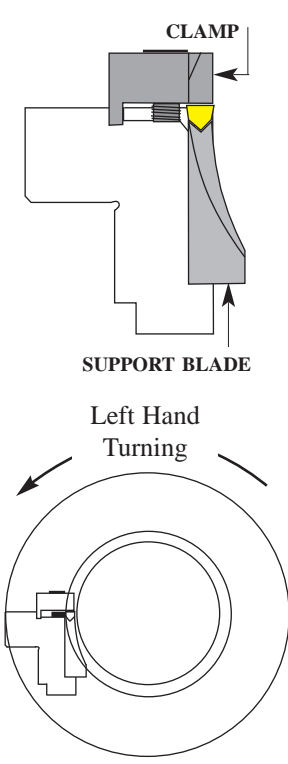
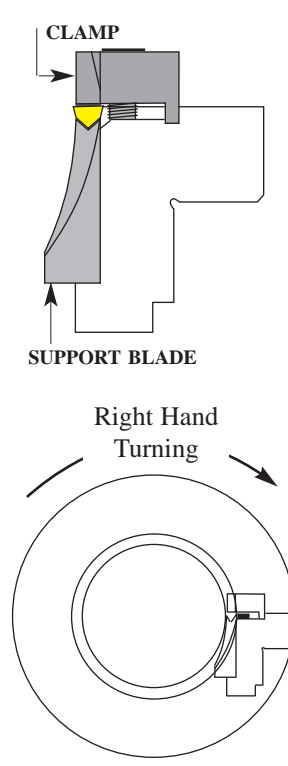
R.H. HOLDER L.H. TURNING	Outer-Ø*			Ordering code support blade	Stock standard		Ordering code clamp	Stock standard		
	mm.	CW	CD							
 <p>CLAMP</p> <p>SUPPORT BLADE</p> <p>Left Hand Turning</p>	70 - 100	6	40	1502 64006 1	■		1503 64006 1	■		
		10	40	1502 64010 1	■		1503 64010 1	■		
		10	50	1502 65010 1	■		1503 65010 1	■		
	100 - 140	6	40	1502 64006 2	■		1503 64006 1	■		
		10	40	1502 64010 2	■		1503 64010 1	■		
		10	60	1502 66010 2	■		1503 66010 1	■		
	135 - 190	6	50	1502 65006 3	■		1503 65006 3	■		
		10	50	1502 65010 3	■		1503 65010 3	■		
		10	70	1502 67010 3	■		1503 67010 3	■		
	170 - 250	6	50	1502 65006 4	■		1503 65006 3	■		
		10	50	1502 65010 4	■		1503 65010 3	■		
		10	85	1502 68510 4	■		1503 68510 3	■		
	245 - 400	6	50	1502 65006 5	■		1503 65006 3	■		
		10	50	1502 65010 5	■		1503 65010 3	■		
		10	100	1502 610010 5	■		1503 610010 3	■		
	395 - ~	6	50	1502 65006 6	■		1503 65006 3	■		
		10	50	1502 65010 6	■		1503 65010 3	■		
		10	100	1502 610010 6	■		1503 610010 3	■		
	L.H. HOLDER R.H. TURNING	Outer-Ø*			Ordering code support blade	Stock standard		Ordering code clamp	Stock standard	
	mm.	CW	CD							
	 <p>CLAMP</p> <p>SUPPORT BLADE</p> <p>Right Hand Turning</p>	70 - 100	6	40	1502 54006 1	■		1503 54006 1	■	
			10	40	1502 54010 1	■		1503 54010 1	■	
			10	50	1502 55010 1	■		1503 55010 1	■	
		100 - 140	6	40	1502 54006 2	■		1503 54006 1	■	
10			40	1502 54010 2	■		1503 54010 1	■		
10			60	1502 56010 2	■		1503 56010 1	■		
135 - 190		6	50	1502 55006 3	■		1503 55006 3	■		
		10	50	1502 55010 3	■		1503 55010 3	■		
		10	70	1502 57010 3	■		1503 57010 3	■		
170 - 250		6	50	1502 55006 4	■		1503 55006 3	■		
		10	50	1502 55010 4	■		1503 55010 3	■		
		10	85	1502 58510 4	■		1503 58510 3	■		
245 - 400		6	50	1502 55006 5	■		1503 55006 3	■		
		10	50	1502 55010 5	■		1503 55010 3	■		
		10	100	1502 510010 5	■		1503 510010 3	■		
395 - ~		6	50	1502 55006 6	■		1503 55006 3	■		
		10	50	1502 55010 6	■		1503 55010 3	■		
		10	100	1502 510010 6	■		1503 510010 3	■		

SPARE PARTS FOR FACE GROOVING

(SUPPORT BLADE ARE SUITABLE FOR BOTH R.H. AND L.H. HOLDERS)

FOR HOLDERS, SEE PAGE 31.

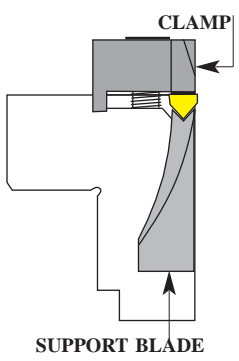
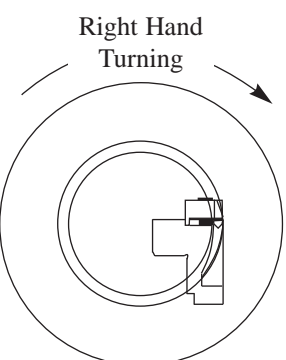
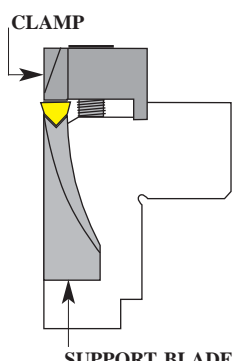
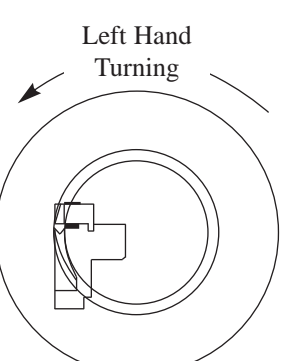
R.H. HOLDER R.H. TURNING	Outer* mm.	CW	CD	Ordering code support blade	Stock standard	Ordering code clamp	Stock standard	
	 <p>CLAMP</p> <p>SUPPORT BLADE</p> <p>Right Hand Turning</p> 	70 - 100	6	40	1502 54006 1	■	1503 54006 1C	<input type="checkbox"/>
10			40	1502 54010 1	■	1503 54010 1C	■	
10			50	1502 55010 1	■	1503 55010 1C	<input type="checkbox"/>	
100 - 140		6	40	1502 54006 2	■	1503 54006 1C	<input type="checkbox"/>	
		10	40	1502 54010 2	■	1503 54010 1C	<input type="checkbox"/>	
		10	60	1502 56010 2	■	1503 56010 1C	<input type="checkbox"/>	
135 - 190		6	50	1502 55006 3	■	1503 55006 3C	<input type="checkbox"/>	
		10	50	1502 55010 3	■	1503 55010 3C	■	
		10	70	1502 57010 3	■	1503 57010 3C	<input type="checkbox"/>	
170 - 250		6	50	1502 55006 4	■	1503 55006 3C	<input type="checkbox"/>	
		10	50	1502 55010 4	■	1503 55010 3C	<input type="checkbox"/>	
		10	85	1502 58510 4	■	1503 58510 3C	<input type="checkbox"/>	
245 - 400		6	50	1502 55006 5	■	1503 55006 3C	<input type="checkbox"/>	
		10	50	1502 55010 5	■	1503 55010 3C	<input type="checkbox"/>	
		10	100	1502 510010 5	■	1503 510010 3C	<input type="checkbox"/>	
395 - ~		6	50	1502 55006 6	■	1503 55006 3C	<input type="checkbox"/>	
		10	50	1502 55010 6	■	1503 55010 3C	<input type="checkbox"/>	
		10	100	1502 510010 6	■	1503 510010 3C	<input type="checkbox"/>	
L.H. HOLDER L.H. TURNING		Outer-Ø* mm.	CW	CD	Ordering code support blade	Stock standard	Ordering code clamp	Stock standard
 <p>CLAMP</p> <p>SUPPORT BLADE</p> <p>Left Hand Turning</p> 		70 - 100	6	40	1502 64006 1	■	1503 64006 1C	■
			10	40	1502 64010 1	■	1503 64010 1C	<input type="checkbox"/>
			10	50	1502 65010 1	■	1503 65010 1C	<input type="checkbox"/>
		100 - 140	6	40	1502 64006 2	■	1503 64006 1C	■
			10	40	1502 64010 2	■	1503 64010 1C	<input type="checkbox"/>
	10		60	1502 66010 2	■	1503 66010 1C	<input type="checkbox"/>	
	135 - 190	6	50	1502 65006 3	■	1503 65006 3C	■	
		10	50	1502 65010 3	■	1503 65010 3C	<input type="checkbox"/>	
		10	70	1502 67010 3	■	1503 67010 3C	<input type="checkbox"/>	
	170 - 250	6	50	1502 65006 4	■	1503 65006 3C	■	
		10	50	1502 65010 4	■	1503 65010 3C	<input type="checkbox"/>	
		10	85	1502 68510 4	■	1503 68510 3C	<input type="checkbox"/>	
	245 - 400	6	50	1502 65006 5	■	1503 65006 3C	■	
		10	50	1502 65010 5	■	1503 65010 3C	<input type="checkbox"/>	
		10	100	1502 610010 5	■	1503 610010 3C	<input type="checkbox"/>	
	395 - ~	6	50	1502 65006 6	■	1503 65006 3C	■	
		10	50	1502 65010 6	■	1503 65010 3C	<input type="checkbox"/>	
		10	100	1502 610010 6	■	1503 610010 3C	<input type="checkbox"/>	

* See page 23

Ordering example: 3 pieces 1502 65006 5

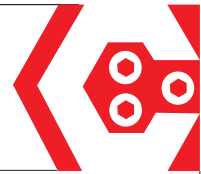

NOTE: Toolholders are supplied with screw for clamp only.
Clamps, keys and inserts must be ordered separately.
For inserts, see page 12 - 13.

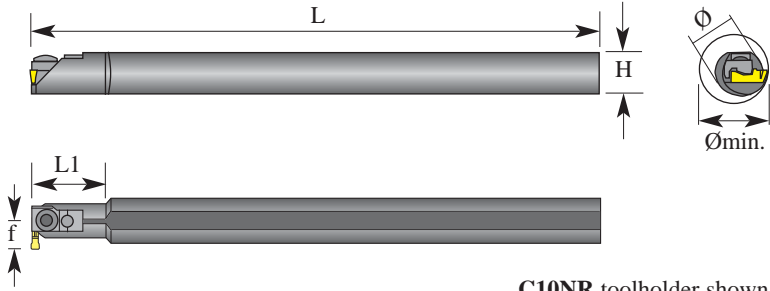

C10NR toolholder shown

TOOLHOLDERS AND CLAMPS FOR R.H. INTERNAL GROOVING											
				R.H. TOOLHOLDER			R.H. CLAMP				
CW max.	CD max.	Ø min.	Dimensions					Ordering code holder	Stock standard	Ordering code clamp	Stock standard
			Ø	f	H	L	L1				
2,5	2	10	10	6	9,5	150	20	C10NR 10	■	400 10 R	■
2,5	2,5	12	12	7	11,4	150	20	C10NR 12	■	400 12 R	■
2,5	3	16	16	8	15,3	180	25	C10NX 16	■	400 16 R	■
2,5	3	20	20	8	15,3	180	25	C10NX 20	■	400 20 R	■

TOOLHOLDERS AND CLAMPS FOR L.H. INTERNAL GROOVING											
				L.H. TOOLHOLDER			L.H. CLAMP				
CW max.	CD max.	Ø min.	Dimensions					Ordering code holder	Stock standard	Ordering code clamp	Stock standard
			Ø	f	H	L	L1				
2,5	2	10	10	6	9,5	150	20	C10NL 10	■	400 10 L	■
2,5	2,5	12	12	7	11,4	150	20	C10NL 12	■	400 12 L	■
2,5	3	16	16	8	15,3	180	25	C10NX 16	■	400 16 L	■
2,5	3	20	20	8	15,3	180	25	C10NX 20	■	400 20 L	■

SPARE PARTS FOR THE C10 SYSTEM

Ordering code	Description	Number per holder
M3 X 7MCB HEX M2	Screw for clamp 400-10-R/L Key for this screw	1
M3 X 8MCB	Screw for clamp 400-12-R/L	1
M3 X 10MCB	Screw for clamp 400-16-R/L 400-20-R/L	1 1
HEX M2	Key for this screw	

C25 BASIC TOOLHOLDER

NOTE: Toolholders are supplied with screw for support blade only.

Clamps, support blades, keys and inserts must be ordered seperately.

For inserts, see page 12-13

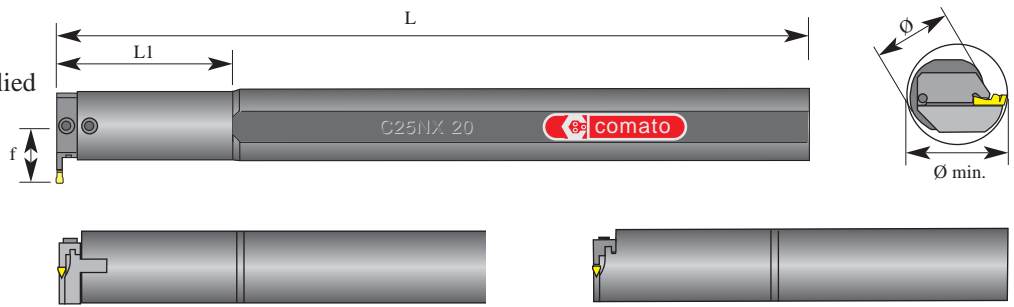

C25NX 20 Toolholder shown with R.H. clamp and support blade.

Holder with fixed support blade are supplied with clamp **405 25250R**

Ø	Dimensions			CW max	CD max	Ordering code holder	Stock standard	Ordering code holder with fixed blade	Stock standard
	f	L	L1						
20	20	200	40	4	10	C25NX 20	■	C25MB 2,5R 20	○
25						C25NX 25	■	C25MB 2,5R 25	○
32						C25NX 32	■	C25MB 2,5R 32	○
40						C25NX 40	■	C25MB 2,5R 40	○

SUPPORT BLADES AND CLAMPS FOR R.H. INTERNAL GROOVING

clamps are supplied including screw.

SUPPORT BLADE			CLAMP			
CW mm.	CD mm.	Ø min.	Ordering code R.H. support blade	Stock standard	Ordering code R.H. clamp	Stock standard
2	5,5	25	305 25200 R	■	405 25200 R	■
2,5			305 25250 R	■	405 25250 R	■
3	10	32	310 32300 R	■	410 32300 R	■
4			310 32400 R	■	410 32400 R	■

SUPPORT BLADES AND CLAMPS FOR L.H. INTERNAL GROOVING

clamps are supplied including screw.

SUPPORT BLADE			CLAMP			
CW mm.	CD mm.	Ø min.	Ordering code L.H. support blade	Stock standard	Ordering code L.H. clamp	Stock standard
2	5,5	25	305 25200 L	■	405 25200 L	■
2,5			305 25250 L	■	405 25250 L	■
3	10	32	310 32300 L	■	410 32300 L	■
4			310 32400 L	■	410 32400 L	■

SPARE PARTS FOR THE C25 SYSTEM

Ordering code	Description	Number per holder
M3 X 16MC HEX M2,5	Screw for clamp Key for clamp screw	1
M5 X 10MSC HEX M2,5	Screw for support blade Key for support blade screw	1

C50 - SYSTEM

SYSTEM FOR INTERNAL GROOVING Ø50 MM. AND ABOVE

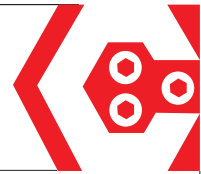

C50 TOOLHOLDER

NOTE: Toolholders are supplied with screws for support blade and clamp only.
Clamps, support blades, keys and inserts must be ordered separately.
For inserts, see page 6 - 11.

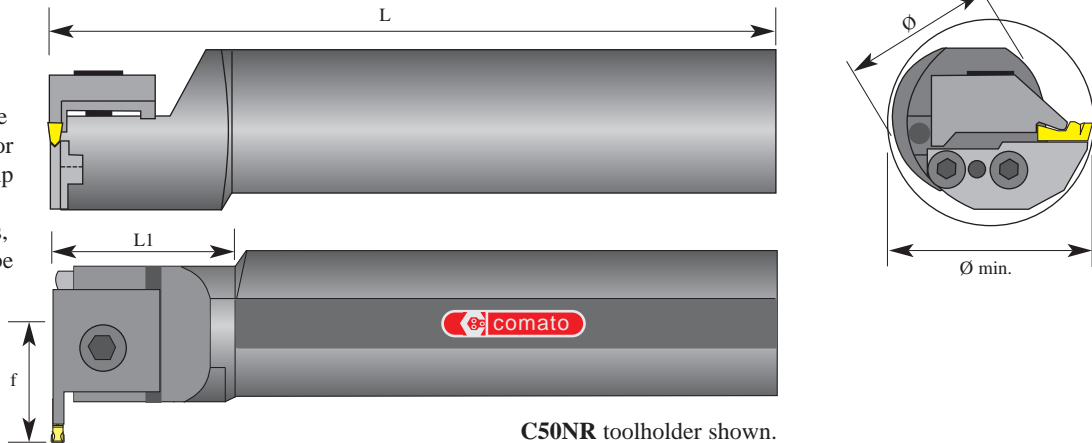

Ø	Dimensions			CW max	CD max	Ordering code R.H. holder	Stock standard	Ordering code L.H. holder	Stock standard
	f	L	L1						
25	33	195	50	5	12	C50NR 25	■	C50NL 25	■
32						C50NR 32	■	C50NL 32	■
40				5	12	C50NR 40	■	C50NL 40	■
50	38	195	50			C50NR 50	□	C50NL 50	□

SUPPORT BLADES AND CLAMPS FOR R.H. INTERNAL GROOVING										
CW mm.			CD mm.		Ø min.		Ordering code R.H. support blade		Stock standard	
3			12		50		150 312 5030 R		■	
4							150 312 5040 R		■	
5							150 312 5050 R		■	

SUPPORT BLADES AND CLAMPS FOR L.H. INTERNAL GROOVING										
CW mm.			CD mm.		Ø min.		Ordering code R.H. support blade		Stock standard	
3			12		50		150 312 5030 L		■	
4							150 312 5040 L		■	
5							150 312 5050 L		■	

SPARE PARTS FOR THE C50 SYSTEM			
Ordering code	Description	Number per holder	
M8 X 16MC HEX M6	Screw for clamp Key for clamp screw	1	
M5 X 16MK HEX M3	Screw for support blade Key for support blade screw	2	

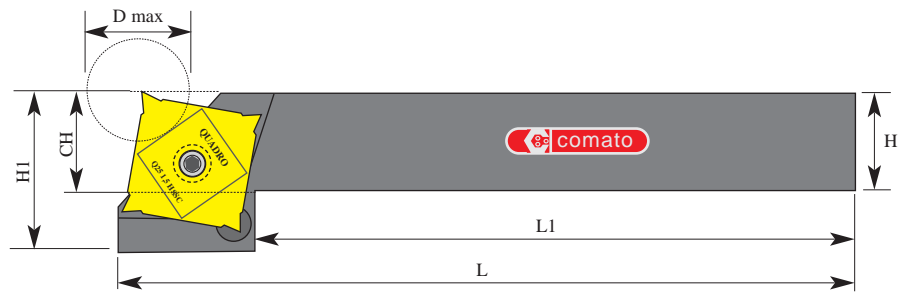

Insert pocket 2 (Links) →

Insert pocket 1 (Rechts) →



INSERTS WITH 0° FRONT ANGLE

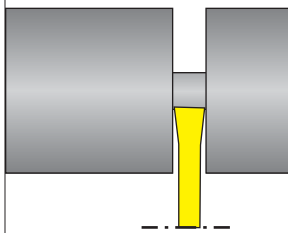
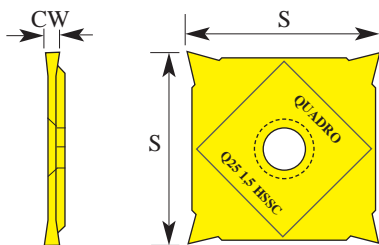

This inserts can be used as **R.H.** inserts as well as **L.H.** inserts.

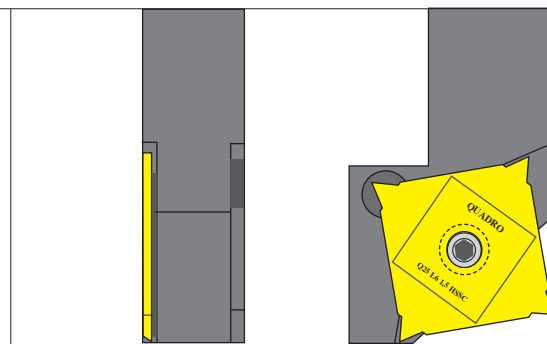

NOTE!

These inserts can only be used as **L.H.** insert in insert pocket (2) (see drawing of toolholder)

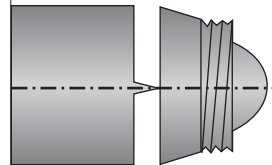

INSERTS WITH 6° OF 12° FRONT ANGLE

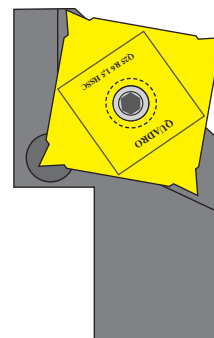
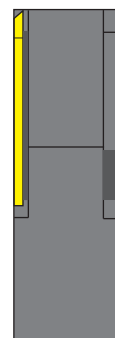

NOTE!

These inserts can only be used as **R.H.** insert in insert pocket (1) (see drawing of toolholder)

CUTTING SPEEDS & FEEDS

Material	Cutting speed m/min.	Feed mm.						
		CW= 0,7~0,9	1,0	1,2	1,5	2,0	2,5	3,0
Unalloyed steel	40 ~ 60	0,05~0,8	0,08~0,1	0,08~0,1	0,1~0,15	0,1~0,2	0,1~0,2	0,1~0,25
Alloyed steel	30 ~ 50	0,04~0,5	0,04~0,06	0,05~0,06	0,05~0,1	0,08~0,15	0,1~0,18	0,1~0,2
Heat resistand steel	30 ~ 40	0,04~0,5	0,04~0,06	0,05~0,06	0,05~0,1	0,08~0,15	0,1~0,18	0,1~0,2
Stainless steel	30 ~ 40	0,04~0,5	0,04~0,06	0,05~0,06	0,05~0,1	0,08~0,15	0,1~0,18	0,1~0,2
Cast iron	20 ~ 30	0,04~0,5	0,04~0,06	0,05~0,06	0,05~0,1	0,08~0,15	0,1~0,18	0,1~0,2
Non-Ferrous materials	~ 150	~0,15	~0,2	~0,2	~0,25	~0,25	~0,25	~0,3

Values are based on a cutting edge lifetime of **15 minutes**.

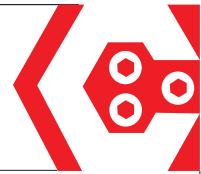

NOTE: Toolholders are supplied with screw and key.

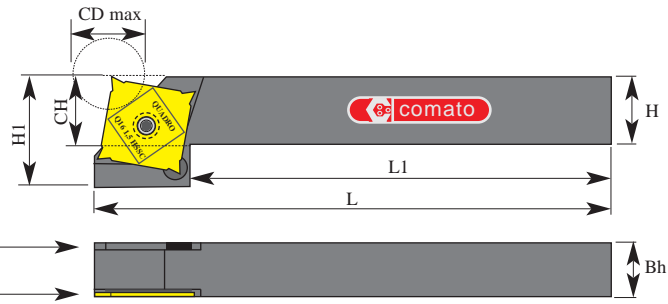

H	Bh	CH	L	L1	H1	CD max.	Insert	Ordering code Holder	Stock standard
10		10				13	Q16	GEX1012K Q16	■
12		12			GEX1212K Q16			■	
14	12	14	125	106	25			GEX1412K Q16	■
16		16						GEX1612K Q16	■
20		20						GEX2012K Q16	■

Diagram	Insert Dimensions (CW, S, CD max.)	Insert Dimensions (CW, S, CD max.)	Ordering code	Stock standard
	CW +0,02, S +0,05, CD max. 13		Q16 0,7 HSSC Q16 0,8 HSSC Q16 0,9 HSSC Q16 1,0 HSSC Q16 1,2 HSSC Q16 1,5 HSSC	■ ■ ■ ■ ■ ■
	CW +0,02, S +0,05, CD max. 13		Q16 R6 1,2 HSSC Q16 R6 1,5 HSSC Q16 R12 1,2 HSSC Q16 R12 1,5 HSSC	■ ■ ■ ■
	CW +0,02, S +0,05, CD max. 13		Q16 L6 1,2 HSSC Q16 L6 1,5 HSSC Q16 L12 1,2 HSSC Q16 L12 1,5 HSSC	■ ■ ■ ■

TUBE CUTTING DATE	Diagram	CD	d min.
			50 40 30 25 20 16 13

SPARE PARTS FOR THE QUADRO® Q16 SYSTEM

Ordering code	Description	Number per holder
T9 - M3 CQ - T9	Screw for Q16 insert Key for T9-M3 screw	1 1

comato[®] QUADRO[®]- Q25 - HSS SYSTEM

FOR BURR-FREE PARTING-OFF



NOTE: Toolholders are supplied with screw and key.

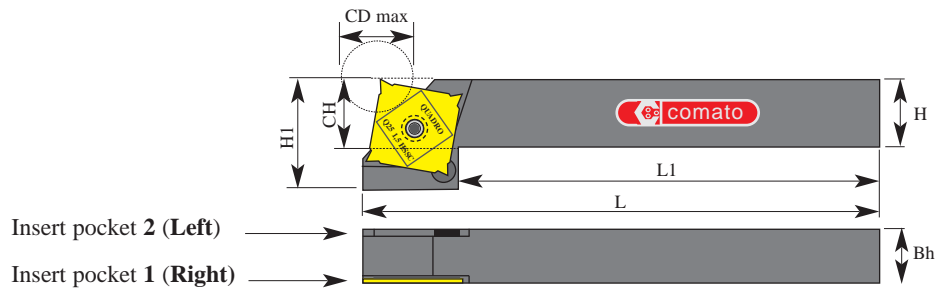

H	Bh	CH	L	L1	H1	CD max.	insert	Ordering code Holder	Stock standard	TUBE CUTTING DATE	CD	d min.
12		12						GEX1216M Q25	■		50	43,4
14		14					GEX1416M Q25	■	40		31,2	
16	16	16	150	125	32	20	Q25	■	30		16,4	
20		20					GEX2016M Q25	■	25		8,4	
25		25					GEX2516M Q25	■	20		0	
32		32					GEX3216M Q25	■	16		0	
20	20	20	200	145	55	40	Q40	■	13	0		
25		25					GEX2525M Q40	■				

	CW	S	CD max.	Ordering code	Stock standard
				+	+
	+0,02	+0,05		Q25 1,0 HSSC	<input type="checkbox"/>
	1,0			Q25 1,5 HSSC	■
	1,5	25	20	Q25 2,0 HSSC	■
	2,0			Q25 2,5 HSSC	■
	2,5			Q25 3,0 HSSC	<input type="checkbox"/>
	+0,02	+0,05		Q25 R6 1,0 HSSC	<input type="checkbox"/>
	1,0		6°	Q25 R6 1,5 HSSC	■
	1,5	25	20	Q25 R6 2,0 HSSC	■
	2,0		6°	Q25 R6 2,5 HSSC	■
	2,5		6°	Q25 R6 3,0 HSSC	<input type="checkbox"/>
	3,0		6°		
	1,5	25	20	Q25 R12 1,5 HSSC	■
2,0		12°	Q25 R12 2,0 HSSC	■	
	+0,02	+0,05		Q25 L6 1,0 HSSC	<input type="checkbox"/>
	1,0		6°	Q25 L6 1,5 HSSC	■
	1,5	25	20	Q25 L6 2,0 HSSC	■
	2,0		6°	Q25 L6 2,5 HSSC	■
	2,5		6°	Q25 L6 3,0 HSSC	<input type="checkbox"/>
	3,0		6°		
	1,5	25	20	Q25 L12 1,5 HSSC	■
2,0		12°	Q25 L12 2,0 HSSC	■	
	+0,02	+0,05		Q40 2,0 HSSC	<input type="checkbox"/>
	2,0	40	40		

SPARE PARTS FOR QUADRO[®] Q25 AND Q40 SYSTEM

Ordering code	Description	Number per holder
T15 - M5 / T25 - M6	Screw for Q25 / Q40 insert	1
CQ - T15 / CQ - T25	Key for T15-M5 / T25-M6 screw	1

Ordering example: 10 pieces Q25 R6 2,0 HSSC

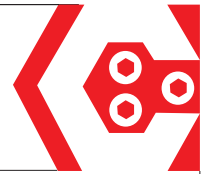

Holder for precision grooving Q16

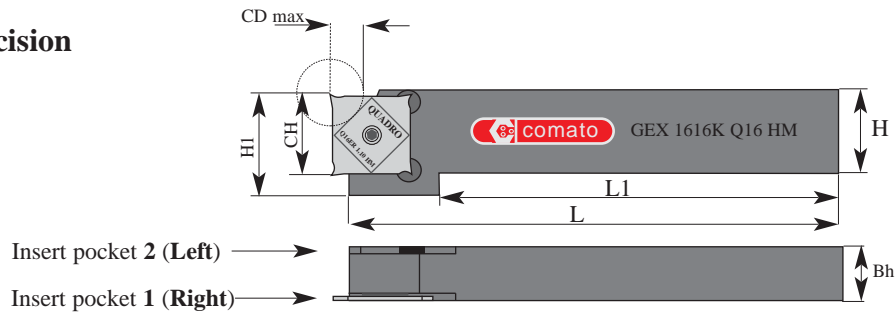

H	Bh	CH	L	L1	H1	Inserts	Ordering code Holder	Stock standard
10	10	10	125	110	20	Q16	GEX1010K Q16 HM	■
12	12	12	125	110	20		GEX1212K Q16 HM	■
16	16	16	125	110	20		GEX1616K Q16 HM	■
20	16	20	125		20		GEX2016K Q16 HM	□
20	20	20	125		20		GEX2020K Q16 HM	■
25	25	25	125		20		GEX2525K Q16 HM	■

Insert for precision parting-off HM P30 TCN Coated	CW -0,05	Circlip max.	CD	Ordering code	Stock stand. P30TCN
		0,57 mm.	0,4	3,00	Q16ER 0,50 HM
	0,67 mm.	0,5	3,00	Q16ER 0,60 HM	■
	0,77 mm.	0,6	3,00	Q16ER 0,70 HM	■
	0,87 mm.	0,7	6,50	Q16ER 0,80 HM	■
	0,97 mm.	0,8	6,50	Q16ER 0,90 HM	■
	1,07 mm.	0,9	6,50	Q16ER 1,00 HM	■
	1,24 mm.	1,0	6,50	Q16ER 1,10 HM	■
	1,44 mm.	1,2	6,50	Q16ER 1,30 HM	■
	1,74 mm.	1,5	6,50	Q16ER 1,60 HM	■
	1,99 mm.	1,75	6,50	Q16ER 1,85 HM	■
	2,29 mm.	2,0	6,50	Q16ER 2,15 HM	■
	2,79 mm.	2,5	6,50	Q16ER 2,65 HM	■
	3,29 mm.	3,0	6,50	Q16ER 3,15 HM	■
	4,29 mm.	4,0	6,50	Q16ER 4,15 HM	■
	5,29 mm.	5,0	6,50	Q16ER 5,15 HM	■

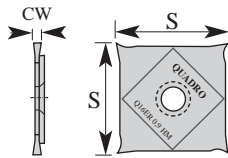

SPARE PARTS FOR THE QUADRO® Q16 SYSTEM

Ordering code	Description	Number per holder
T9 - M3	Screw for Q16 insert	1
CQ - T9	Key for T9-M3 screw	1

Holder for precision grooving Q25

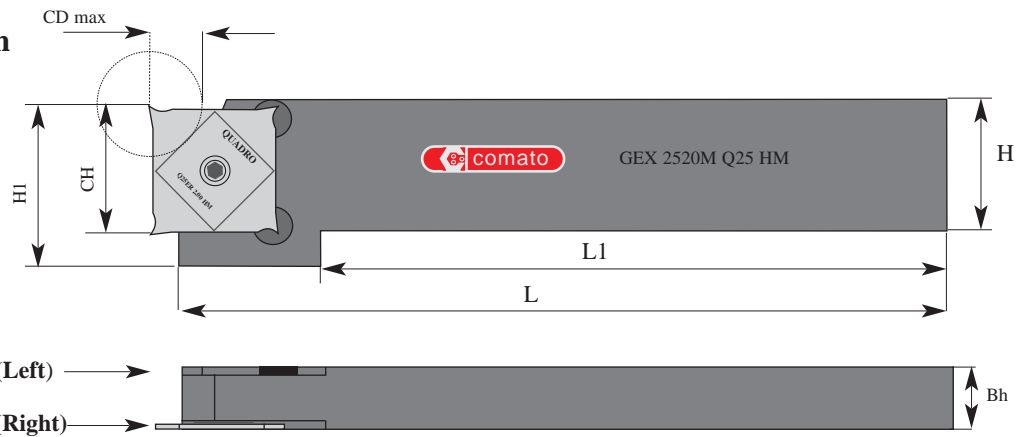

H	Bh	CH	L	L1	H1	Insert	Ordering code Holder	Stock standard
16	16	16	150	125	32	Q25	GEX1616M Q25 HM	■
16	20	16	150	125	32		GEX1620M Q25 HM	□
20	20	20	150	125	32		GEX2020M Q25 HM	■
25	20	25	150	125	32		GEX2520M Q25 HM	□
25	25	25	150	125	32		GEX2525M Q25 HM	■
32	20	32	150		32		GEX3220M Q25 HM	□

Insert for precision parting-off HM P30 TCN Coated

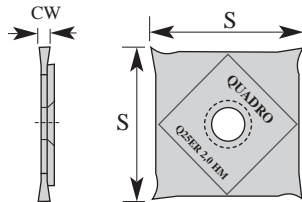

CW -0,05	Circlip max.	CD	Ordering code	Stock stand. P30TCN
1,00 mm.		10	Q25ER 1,00 HM	□
1,50 mm.		10	Q25ER 1,50 HM	□
2,00 mm.		10	Q25ER 2,00 HM	■
2,50 mm.		10	Q25ER 2,50 HM	■
3,00 mm.		10	Q25ER 3,00 HM	■
3,50 mm.		10	Q25ER 3,50 HM	□
4,00 mm.		10	Q25ER 4,00 HM	■
4,29 mm.	4,0	10	Q25ER 4,15 HM	
5,00 mm.		10	Q25ER 5,00 HM	■
5,29 mm.	5,0	10	Q25ER 5,15 HM	

SPARE PARTS FOR THE QUADRO[®] Q25 SYSTEM

Ordering code	Description	Number per holder
T15 - M5	Screw for Q25 insert	1
CQ - T15	Key for T15-M5 screw	1

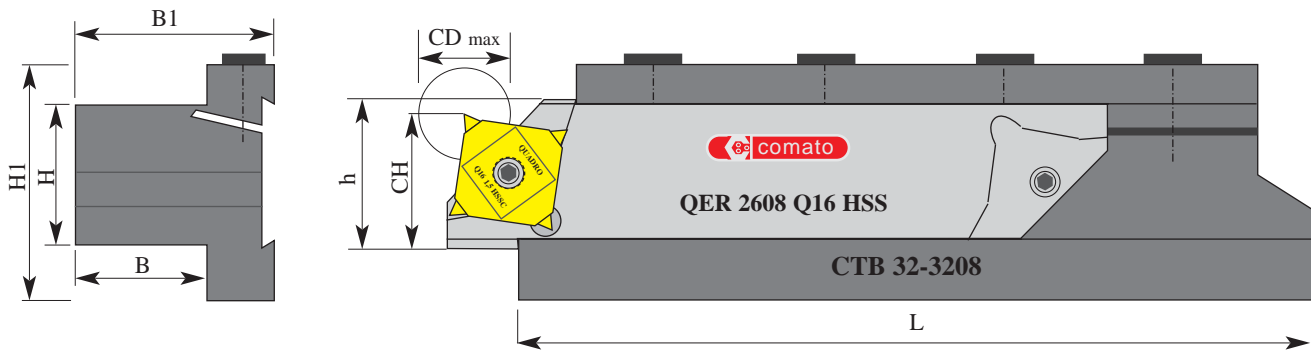
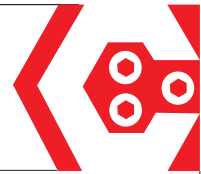

h	H	B	L	H1	B1	Holder Q16	Stock	h	H	B	L	H1	B1	Holder Q25	Stock
26	16	16	76	38	30	CTB16 2608	■	32	25	22	120	48	38	CTB25 3208	■
26	20	19	87	38	33	CTB20 2608	■	32	32	28,5	120	48	44,5	CTB32 3208	■

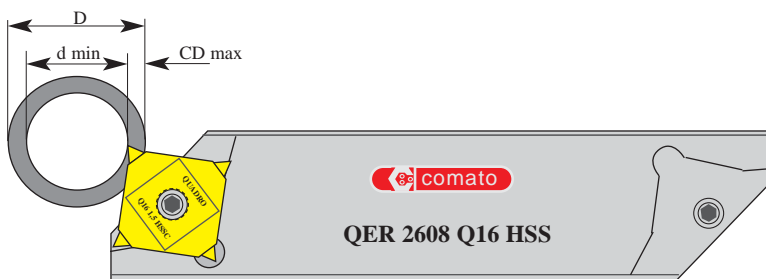

CD max	Q16 HSS dmin	Q16 HM dmin	Q25 HSS dmin	Q25 HM dmin
12,5	0	0	0	0
20	12,5	12,5	0	0
25	19	19	10	10
30	25	25	16	16
40	36	36	32	32
50	47	47	44	44
75	73	73	71	71
100			97	97
125			123	123

Quadro® HSS support blade

NOTE: Supportblades are supplied with screw and key. For inserts, see page 38 - 39.

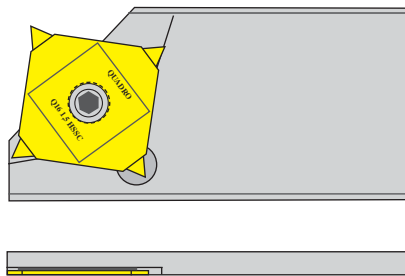

Quadro® HM support blade

NOTE: Supportblades are supplied with screw and key. For inserts, see page 40 - 41.

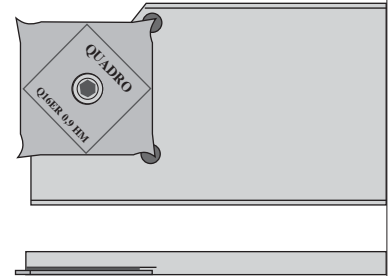

CH	h	CW	L	Ordering code HSS support blade	Stock standard	Ordering code HM support blade	Stock standard
21,4	26	8	110	QER 2608 Q16 HSS	■	QER 2608 Q16 HM	■
21,4	26	8	110	QEL 2608 Q16 HSS	■	QEL 2608 Q16 HM	■
21,4	26	8	110	QER/L 2608 Q16 HSS	■	QER/L 2608 Q16 HM	■
25	32	8	150	QER 3208 Q25 HSS	■	QER 3208 Q25 HM	■
25	32	8	150	QEL 3208 Q25 HSS	■	QEL 3208 Q25 HM	■
25	32	8	150	QER/L 3208 Q25 HSS	■	QER/L 3208 Q25 HM	■

SPARE PARTS FOR QUADRO® SYSTEM

Ordering code	Description	Number per support blade
T9 - M3	Screw for Q16 insert	2
CQ - T9	Key for T9-M3 screw	1
T15 - M5	Screw for Q25 insert	2
CQ - T15	Key for T15-M5 screw	1

Comato grooveturn kits



For Grooveturn system, page 18 and 19 from this catalog.

	Comato kit	1x Holder	1x Clamp		20x Insert	Stock	
3 mm	GT1	GER 2025K 3	CER20-3		150.3.GT.P30C	■	
3 mm	GT2	GER 2525M 3	CER20-3		150.3.GT.P30C	■	
4 mm	GT3	GER 2525M 4	CER20-4		150.4.GT.P30C	■	

Comato grooveturn kits



For Grooveturn system, page 18 and 19 from this catalog.

	Comato kit	1x Holder	1x Clamp	1x Supp. blade	20x Insert	Stock	
3 mm	GT4	GER 2025K B20	CER20-3	BEX20-3	150.3.GT.P30C	■	
3 mm	GT5	GER 2525M B20	CER20-3	BEX20-3	150.3.GT.P30C	■	
4 mm	GT6	GER 2525M B20	CER20-4	BEX20-4	150.4.GT.P30C	■	

Comato Quadro® HSS kits



For Quadro system, page 38 and 39 from this catalog.

Quadro kit	1x Holder	5x Insert	5x Insert	Stock	
PO12	GEX 1212K Q16	Q16 1,0 HSSC	Q16 1,5 HSSC	■	
PO20	GEX 2016M Q25	Q25 1,5 HSSC	Q25 2,0 HSSC	■	

Kit	1x Holder	2x Insert	2x Insert	2x Insert	Stock	
PO12 Mix	GEX 1212K Q16	Q16 0,7 HSSC Q16 1,0 HSSC	Q16 0,8 HSSC Q16 1,2 HSSC	Q16 0,9 HSSC Q16 1,5 HSSC	■	

Comato Quadro® HM kits



For Quadro system, page 40 and 41 from this catalog.

Quadro kit	1x Holder	5x Insert	5x Insert	Stock	
HM12	GEX 1212K Q16 HM	Q16ER 1,3 HMP30TCN	Q16ER 1,6 HMP30TCN	■	
HM20	GEX 2020M Q25 HM	Q25ER 1,5 HMP30TCN	Q25ER 2,0 HMP30TCN	■	

Kit	1x Holder	2x Insert	2x Insert	2x Insert	Stock	
HM12 Mix	GEX 1212K Q16HM	Q16ER 0,90 P30TCN Q16ER 1,60 P30TCN	Q16ER 1,10 P30TCN Q16ER 1,85 P30TCN	Q16ER 1,30 P30TCN	■	

Ordering example: 3 pieces PO12 kit

Distributor



Comadex B.V.

Zepto 2

6902 KE Zevenaar - The Netherlands

Tel.: +31 - 316 - 243990

Fax: +31 - 316 - 342680

E-Mail: info@comadex.nl

www.comadex.nl